



Special caliper

S_Cal EVO

DESCRIPTION

SMART POINTS JAWS

- High-quality, ergonomic caliper with integrated Bluetooth® system
- Equipped with interchangeable M2.5 keys with hard metal ball Ø 2.5 mm, for all kinds of internal measurements from 34 mm with these keys.
- 3.5 mm thick hardened and ground stainless steel frame
- New extra-large display unit with 11.5 mm high digits
- Convenient push button for sending data that can also be programmed with another function
- Memorising the original position even when the instrument is switched off
- Measuring range 150 mm with rectangular depth rod
- Protection class IP67
- Wheel available as an option

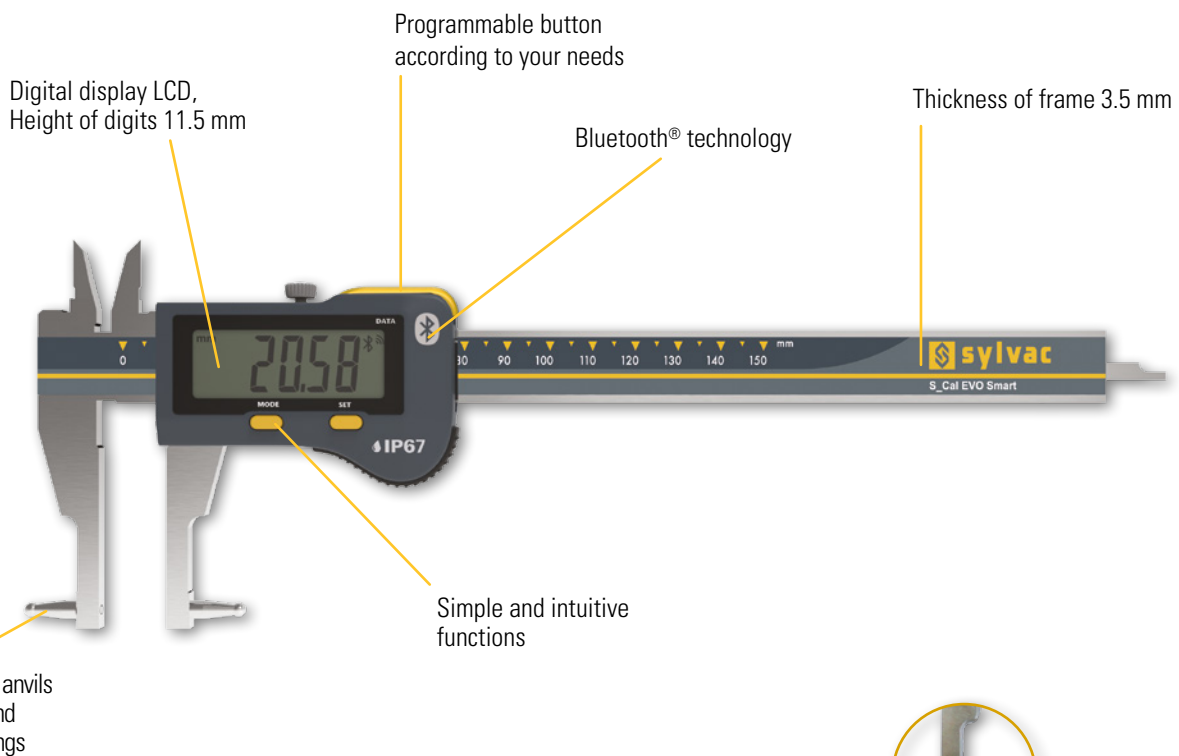

ISO 13385-1



SIS Smart Inductive System



IP67

* SIS description on page 5



M2.5

Interchangeable anvils



Special caliper

S_Cal EVO

DIMENSIONAL DRAWING

SMART POINTS JAWS

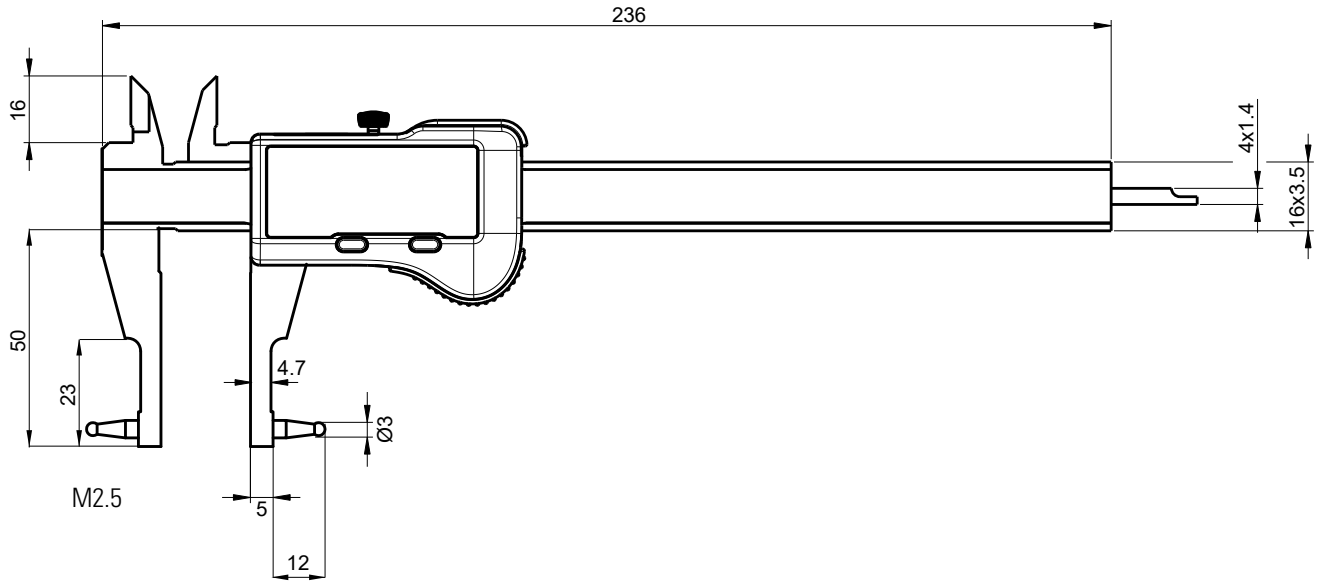

C

TECHNICAL SPECIFICATIONS

		810-1601
Measuring range	mm	150
Max. Error G - external measurements	µm	20 ¹⁾
Max. Error - internal measurements	µm	20-30 ²⁾
Depth rod	mm	4 x 1.4
Protection rating according to IEC 60529		IP67
Output data		Bluetooth® wireless technology*
Functions		Zero setting, Preset (max 999.99), mm/inch, Hold, Data
Smart Inductive Sensor		●

¹⁾ 0-150 mm : 20 µm / ISO13385-1

²⁾ Ø4-25 : 20 µm / ISO13385-1
Ø26-150 : 30 µm / ISO13385-1

*** Up to 8 instruments connected per dongle #981-7100**



Partkey to screw/unscrew the anvils