

CONTENTS



HEIGHT GAUGES

TVM	5
V/V Plus	11
Vectra Touch	17
Mestra/Mestra Touch	23
Accessories for height gauges	29



HORIZONTAL MEASURING INSTRUMENTS

TELS	41
Alesta	47
Horizon/Horizon Granite	53
Horizon Premium (HPA/HPD)	61
THV	69
Labconcept/Labconcept Premium	75
Labconcept Nano	85
Accessories for Horizontal instruments	93
Twiner	113
Accessories for Twinner	121

SURFACE ANALYSIS INSTRUMENTS



TR Profile/TR Profile DH-8	127
TR Scan	135
TR Scan Premium	143
Accessories for Surface instruments	151

PRESENTATION

TRIMOS GENERAL CATALOG

Dear Customer, dear Reader,

In an industrial world where quality control becomes more and more important, Trimos is proud to be able to offer a large range of solutions responding to dimensional measurement needs. Each instrument has its specific application and definitely solves all required tasks. Our products combine high precision, innovation, advanced design and ease of use.

Since 1972, Trimos has managed to position itself as the leader in its fields of activity and guarantees a "Swiss Made" manufacturing quality level.

Trimos is focused on 3 segments in the dimensional metrology field:

- Height gauges
- Horizontal measuring instruments
- Surface analysis instruments

We offer «turnkey» solutions based on the following modular items:

- Instruments
- Large range of accessories
- Hardware
- Software and driver programs

Trimos distributes its products in more than 40 countries through a network of agents. With their help, we can offer a large number of services as qualified technical support for selling new instruments, perfect after-sales services and technical training.

If quality is your objective, Trimos is your partner.



Patrice Kemper, CEO

TRIMOS SA

Av.de Longemalle 5
CH - 1020 Renens
T. + 41 21 633 01 01
F. + 41 21 633 01 02
www.trimos.ch

QUALITY

Quality has always been Trimos' main concern. Our company, certified ISO9000 for several years, aims to offer its customers blue chip products and services.

All instruments are developed and produced in our workshops by highly qualified professionals. Therefore, the quality of our products is thoroughly mastered.

By choosing a Trimos instrument, you will benefit of almost 40 years of experience in the metrology field. Hence your certainty to acquire a top-of-the-range instrument bearing the "Swiss Made" label.



LABORATORY

In order to ensure the highest performances of its instruments, Trimos is equipped with a control laboratory provided with the latest technologies.

Thanks to our exclusive **Trimos® Environment Control System**, the control of environmental conditions is fulfilled. Therefore, a faultless follow-up of temperature, humidity and pressure is guaranteed 24/7.

Specifications:
 Temperature: 20 °C ± 0.2
 Humidity: 50% ± 5



SERVICES

In parallel with the sales of instruments, Trimos and its agents offer a wide range of services allowing the most profitable exploitation of its products:

- Technical support
- Training (at Trimos or on site)
- After-sales service
- Repair of instruments
- Upgrade of old instruments
- Calibration
- Customized instruments and accessories
- Software and drivers
- Maintenance contract

Examples of instruments that we can repair:



TELMA



TVA

Instruments subject to upgrade:



TEL



TELMN

WEBSITE

Our website www.trimos.ch is at your disposal. You will find there the latest information in relation with our firm, our products as well as our sales network.

Do not hesitate to contact us.



TVM



TVM

INTRODUCTION

The TVM instruments are perfect for height measurements and scribing work and reliable in all kinds of workshop conditions. The result of an unique, compact design of the instrument is great mobility and extreme stability.

Because of its advanced measuring system, the self-contained working time of the TVM is one year. Therefore it can be used for multiple applications in the workshop area. The simplicity of manipulation allows constant change of the user without any time-consuming training.

The success of the TVM among competitive gauges is outstanding. More than 14'000 instruments are in use worldwide.

Three models are available: with application range from 300 to 1000 mm. A large range of accessories for all kinds of measuring applications is available.

ROBUST AND COMPACT CONSTRUCTION

PERFECT FOR USE IN PRODUCTION AREA

ACCURATE AND RELIABLE MEASUREMENTS





USER FRIENDLY

OPTO-RS232 DATA OUTPUT

RECHARGEABLE BATTERY PACK

TWO MODELS: CAST IRON BASE OR A GRANITE BASE

DESCRIPTION

-  Surfaces
-  2 references
-  Internal/external diameters
-  Tolerances
-  Min/Max/Delta

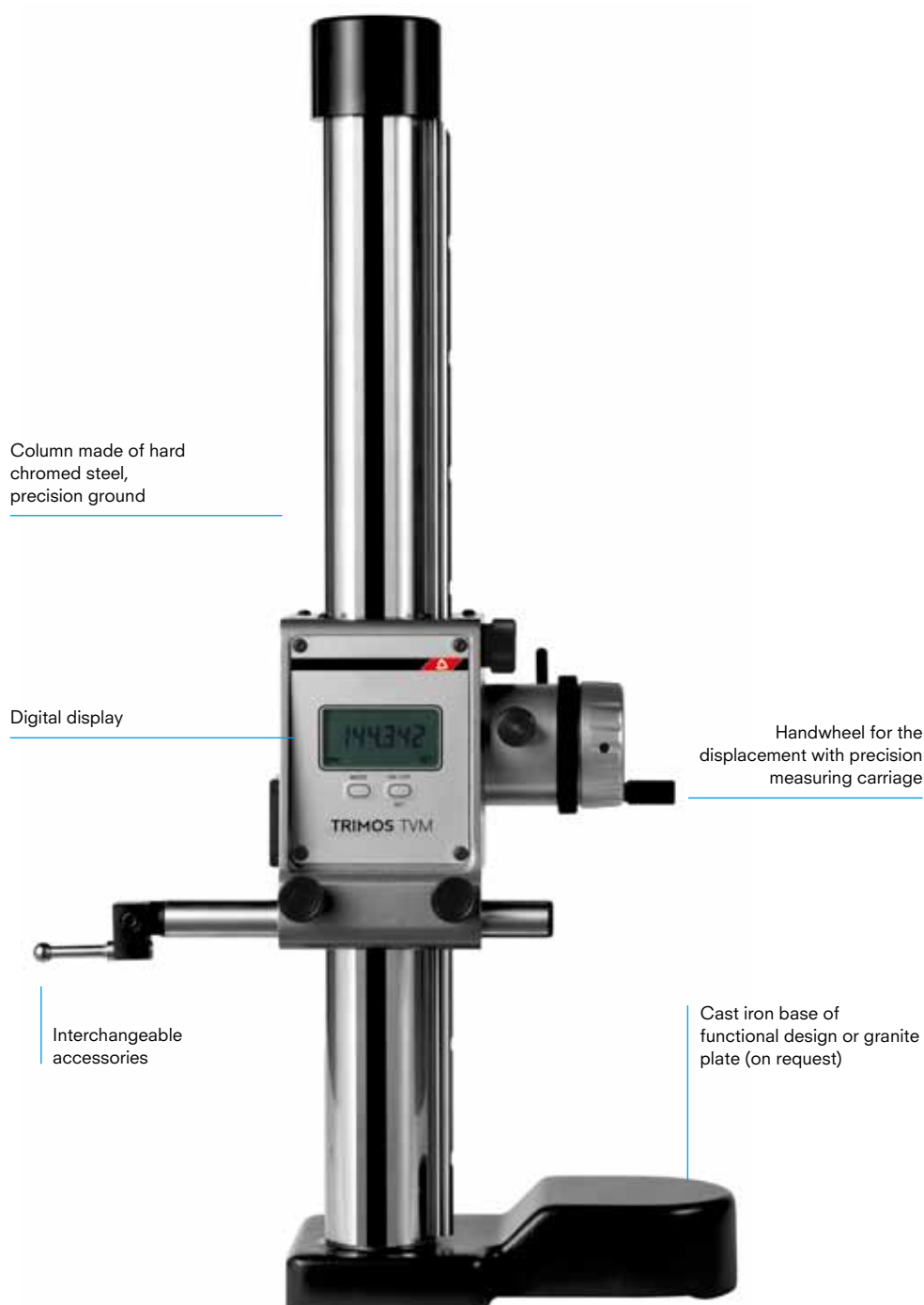

TVM

DISPLAY / SOFTWARE

The clearly defined functions of the display unit allow to collect all height measuring values.

MIN/MAX FUNCTION INDICATOR

2 REFERENCES

END OF BATTERY LIFE WARNING INDICATION

PRESET SELECTION

MEASURING UNIT (MM/IN) INDICATOR

TOLERANCE MODE INDICATOR

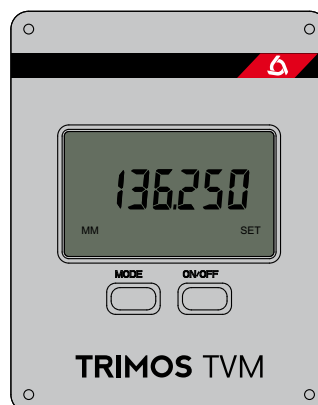

sylvac system



TECHNICAL SPECIFICATIONS

TVM		302	602	1002
Measuring range	mm (in)	320 (12)	620 (24)	1020 (40)
Max. permissible errors ¹⁾	mm	0.02	0.03	0.04
Repeatability (2s) ¹⁾	mm		0.005	
Frontal squareness deviation	mm	0.02	0.03	0.03
Resolutions	mm (in)	0.01/0.001 (.0005/ .00005)		
Measuring force	N		3	
Max. manual carriage displacement speed	mm/s		1500	
Autonomy	h		2000	
Data output			Opto RS232	
Operational temperature	°C		+10 ÷ +40	
Temperature of storage	°C		-10 ÷ +40	
Weight (cast iron base)	kg	6	10	24
Weight (granite base)	kg	14	18	

¹⁾ Values valid with measuring insert and holder (TVM1/1.1/2) at temperature of 20 ± 0.5°C and relative humidity of 50 ± 5%.

DIAGRAM

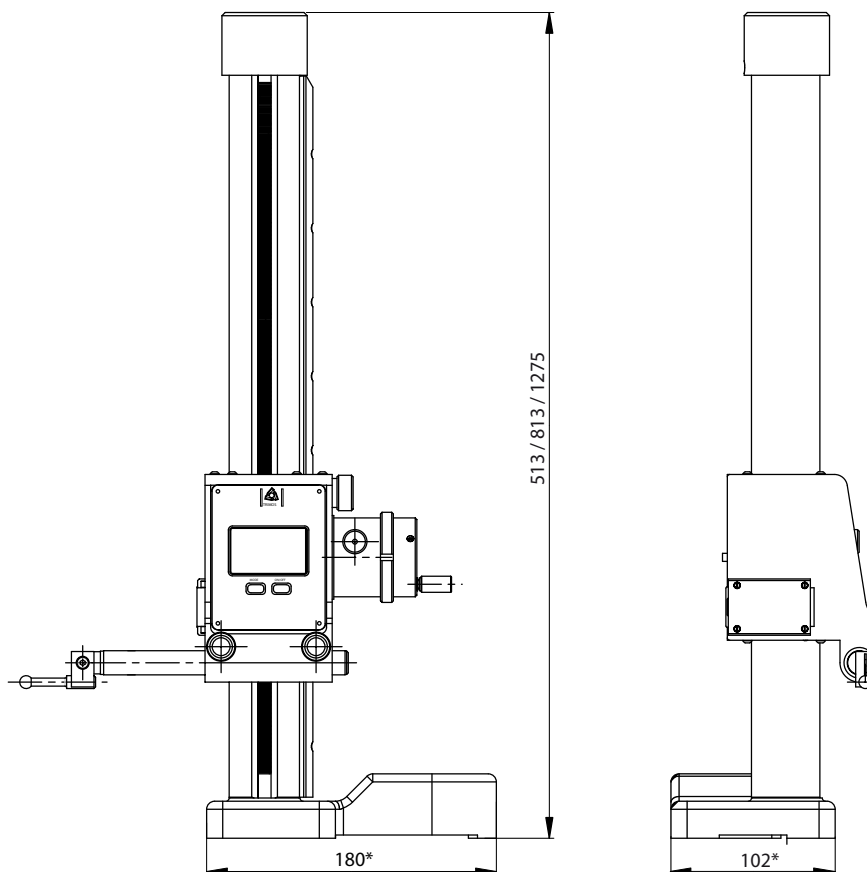

STANDARD INSTRUMENT

The TVM instruments are supplied as follows:

TVM 300- 600	TVM1000
Instrument according to specifications	Instrument according to specifications
Measuring insert and holder (TVM1 / 1.1 / 2)	Measuring insert and holder (TVA1)
Lithium battery, 3 V (BAT-TVM.OPTO)	Lithium battery, 3 V (BAT-TVM.OPTO)
Protection cover (TVM.HO300/600)	User's manual (750 50 0018 03)
User's manual (750 50 0018 03)	Test certificate
Test certificate	

CODE NUMBERS

Cast iron base	Granit base	
TVM302 700 102 10 11	TVM302G 700 102 10 14	Measuring range 300 mm
TVM602 700 102 20 11	TVM602G 700 102 20 14	Measuring range 600 mm
TVM1002 700 102 30 11		Measuring range 1000 mm

* TVM 302 and 602 only

TVM

APPLICATIONS



Height and depth measurements
(TVM1/1.1/2)



Diameter measurements (TVM4)



Measuring of centerline distances
(TVM5)



Scribing (TVM1/TVM3)



Ease of handling

V/V Plus



V/V Plus

INTRODUCTION

Talking about the V and V Plus series means looking at a height measuring instrument of universal use.

The new ergonomic and compact design has been well accepted from the industry worldwide. Ease of use and quick performance of all measuring tasks are given by the clearly defined function keys.

The updated measuring system combined with a powerful display unit guarantees high precision and maintains an incomparable self-containment of use in any manufacturing conditions.

The adjustable measuring force of V Plus models between 0.7 N and 1.6 N (0.3 N on request) allows the performance of measurements on components of delicate material.

The result of a modular instrument concept is a complete series with application ranges from 300 mm to 1235 mm at very competitive prices.

A wide range of accessories makes it possible to solve all required measuring tasks.

PERFECT FOR USE IN THE WORKSHOP AREA

EXTREMELY EASY TO OPERATE

AUTONOMOUS USE WITH RECHARGEABLE BATTERY PACK

AIR CUSHION STANDARD ON C VERSION (V PLUS)

CLEAR DEFINITION OF ALL MEASURING FUNCTIONS







EXTREMELY LARGE DISPLAY OF VALUES

ACCEPTANCE OF A MEASURED VALUE BY ACOUSTIC SIGNAL

DIRECT RS232C DATA OUTPUT (BI-DIRECTIONAL)

ADJUSTABLE MEASURING FORCE

DESCRIPTION

-  Surfaces
-  Internal/external diameters
-  Centerline distances
-  Min/Max/Delta
-  2 references
-  Squareness measurements
-  Calculation mode



V/V Plus

DISPLA / SOFTWARE

The clearly defined functions of the display unit allow quick performance of all required height measurements.

SURFACE AND CENTERLINE DISTANCE MEASUREMENTS

ZERO SETTING OF THE DISPLAY OR PRESET VALUE SETTING

DATA TRANSFER (RS 232)

SELECTION OF MEASURING UNIT MM OR INCH

SELECTOR KEY TO OBTAIN A MIN/MAX/DELTA VALUE

MEASURING USING TWO REFERENCES

ADJUSTMENT OF THE ACOUSTIC SIGNAL



TECHNICAL SPECIFICATIONS

V		300	600
Measuring range	mm (in)	300 (12)	600 (24)
Application range	mm (in)	535 (21)	835 (32)
Max. permissible errors ¹⁾	µm	8	10
Repeatability (2s) ¹⁾	µm	2 (Ø:4)	
Frontal squareness deviation	µm	10	15
Resolutions	mm (in)	0.01/0.001 (.0001/.00005)	
Measuring force	N	1	
Max. manual carriage displacement speed	mm/s	1500	
Autonomy	h	100	
Data output		RS232	
Operational temperature	°C	+10 ÷ +40	
Temperature of storage	°C	-10 ÷ +40	
Weight	kg	10	12

V Plus		300	600	1000
Measuring range	mm(in)	300 (12)	600 (24)	1000 (40)
Application range	mm(in)	535 (21)	835 (32)	1235 (48)
Max. permissible errors ¹⁾	µm	2.5 + L (mm) / 300		
Repeatability (2s) ¹⁾	µm	2		
Frontal squareness deviation	µm	5	8	12
Resolutions	mm(in)	0.01/0.001 (.0001/.00005)		
Measuring force (adjustable)	N	0.7 ÷ 1.6 (V305: 0.3 ÷ 1.2)		
Max. manual carriage displacement speed	mm/s	1500		
Autonomy (without/with air cushion)	h	100/30		
Data output		RS232		
Operational temperature	°C	+10 ÷ +40		
Temperature of storage	°C	-10 ÷ +40		
Weight	kg	10	12	15

¹⁾ Values valid with standard ball probe (TA-MI-101) at temperature of 20 ± 0.5°C and relative humidity of 50 ± 5%.

SCHEMA

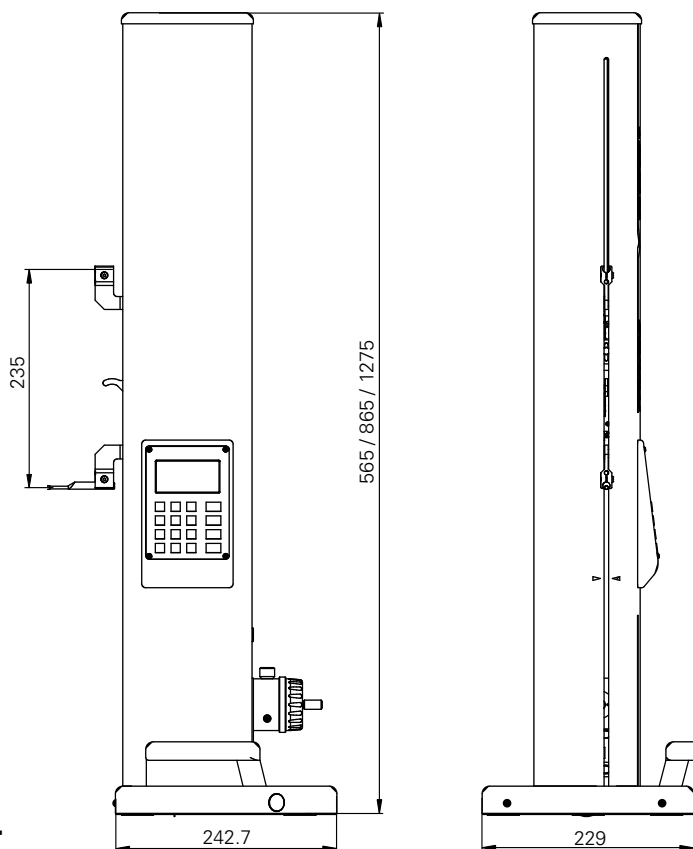

STANDARD INSTRUMENT

The V instruments are supplied as follows:

Instrument according to specifications	User's manual (750 50 0004 00)
Charging unit (TA-EL-131)	Test certificate
Measuring insert with ruby ball Ø 4 mm (TA-MI-101)	Hex screw driver 2 mm (TA-TO-002)
Setting gauge (TA-MG-103)	Hex screw wrench 2.5 mm (V-50.15)

The V Plus instruments are supplied as follows:

Instrument according to specifications	User's manual (750 50 0004 00)
Charging unit (TA-EL-131)	Test certificate
Measuring insert with ruby ball Ø 4 mm (TA-MI-101)	Hex screw driver 2 mm (TA-TO-002)
Setting gauge (TA-MG-103)	Hex screw wrench 2.5 mm (V-50.15)
Protection cover (V.HO300/V.HO600/V.HO1000)	

CODE NUMBERS

V	V Plus		
	Without air cushion	With air cushion	
VL300 700 105 10 41	V304 700 105 10 01	V304C 700 105 10 02	Measuring range 300 mm
	V305 700 105 10 10	V305C 700 105 10 11	Measuring range 300 mm ¹⁾
VL600 700 105 20 41	V604 700 105 20 01	V604C 700 105 20 02	Measuring range 600 mm
		V1004C 700 105 30 02	Measuring range 1000 mm

¹⁾ The instruments V305 and V305C are with low measuring force (0.3-1.2 N)

V/V Plus

APPLICATIONS



Checking of squareness deviation

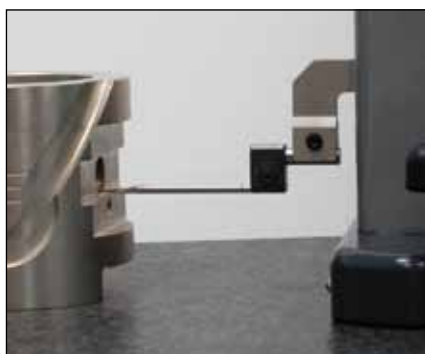

Tiny Surface, diameter and centerline distance measurements (V-5/V50.9)



Depth measurement (TA-IH-109/V-50.5/V-50.4)



Checking of surface distances (TA-MI-101)



Thickness measurements (TA-MI-101)



Min/max measurements (TA-MI-101)

VECTRA-TOUCH



VECTRA-TOUCH

INTRODUCTION

The "Vectra-Touch" height measuring instruments are of universal use in any production field. They are the result of 40 years of experience in development and manufacturing. This experience makes it possible to introduce a product that combines ergonomic design with new technology. Its reliable concept is a reference for durability. Ease of use and quick performance of all required measuring tasks allow unlimited applications in any manufacturing area.

The distinctive design of the Vectra-Touch, as well as its exceptional functionalities, offer the user an ease of use unequalled on the market. The display unit is identical for all models and gathers all assets for a rational use in the workshop. A limited number of keys (19) makes the instrument accessible to any user, whatever his level of training. The robust colour touch screen offers great ease of use. Only essential information will be provided to the user. A graphic assistance guides the execution of all measurements.

Ease of use has been an absolute priority in the requirements, thus resulting in functions, usually considered as complex, such as 2D, programming, statistics, becoming child's play.

CLEAR DISPLAY WITH LARGE DIGITS

GRAPHIC HELP FOR MEASURING

PRINTING OF REPORTS ON USB PRINTER

BACKUP ON EXTERNAL SUPPORT (USB KEY)



















MEASURING RANGE FROM 300 MM TO 2000 MM

AVAILABLE IN MANUAL OR MOTORIZED VERSION

WORKING ON ACCUMULATOR

LARGE RANGE OF ACCESSORIES

DESCRIPTION

-  Surfaces
-  Internal/external diameters
-  Centerline distances
-  Graphic help "EasyScan"
-  Min/Max/Delta
-  9 references
-  Squareness measurements
-  Angle measurements
-  Calculation mode
-  Tolerances
-  2D measuring mode
-  Measurement sequences
-  Statistical analysis
-  Temperature compensation
-  Online help
-  USB ports
-  RS232 ports
-  Wireless communication
-  Automatic displacement



VECTRA-TOUCH

DISPLAY / SOFTWARE

The colour display facilitates the reading of all measuring parameters. The functions are easily and directly accessible. The display unit is identical for all models.

VERY SIMPLE GRAPHIC INTERFACE

DATE AND TIME DISPLAY

DISPLAY OF ENVIRONMENTAL TEMPERATURE

ACOUSTIC AND GRAPHIC PROBING INDICATOR

GRAPHIC DISPLAY OF SQUARENESS

COLOR TOUCH SCREEN

MEASURING IN 2D MODE

PROGRAMMING OF MEASURING SEQUENCES

STATISTICAL ANALYSIS

TEMPERATURE COMPENSATION FEATURE

INTEGRATED ON LINE HELP

BUFFER WITH 999 VALUES



Touch-screen with intuitive interface

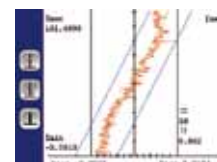

Graphic display of squareness

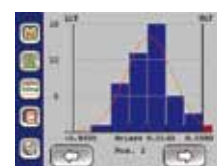

Statistical analysis of measurement results



Graphic help for each function

TECHNICAL SPECIFICATIONS

Vectra-Touch		300	600	1000	1500	2000
Measuring range	mm(in)	305 (12)	610 (24)	1016 (40)	1524 (60)	2034 (80)
With second probe holder	mm(in)	567 (22)	872 (34)	1278 (50)	1786 (70)	2296 (90)
Max. permissible errors ¹⁾	µm	2+ L(mm)/400			2.5 + L(mm)/300	
Repeatability (2s) ¹⁾	µm	1 (Ø:2)				
Resolutions	mm(in)	0.01/0.001/0.0001 (.001/.0001/.00001)				
Manual carriage displacement speed	mm/s	1000				
Motorized carriage displacement speed	mm/s	150				
Measuring force (adjustable)	N	0.5 ÷ 1.8				
Frontal squareness deviation	µm	4	6	10	15	25
Autonomy	h	> 8				
Data output		2 x RS232 C and 2 x USB (A et B)				
Operational temperature	°C	+10 ÷ +40				
Temperature of storage	°C	-10 ÷ +40				
Weight	kg	22	25	29	39	44

¹⁾ Values valid with standard ball probe (TA-MI-101) at temperature of 20 ± 0.5°C and relative humidity of 50 ± 5%.

SCHEMA

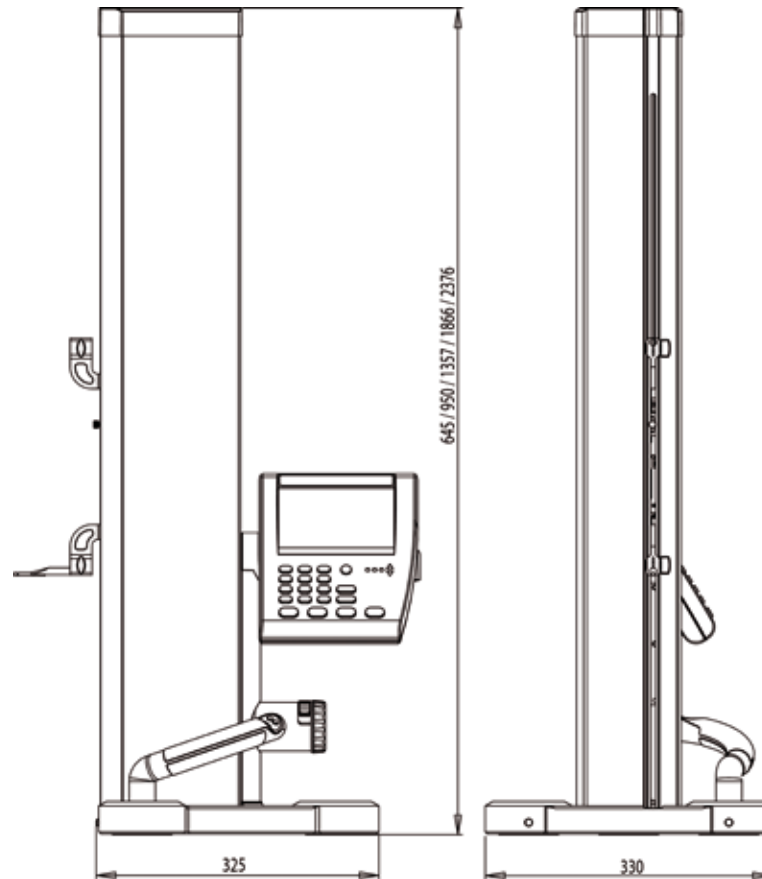

STANDARD INSTRUMENT

The Vectra-Touch instruments are supplied as follows:

Instrument according to specifications	User's manual (750 50 0002 03)
Charging unit (TA-EL-130)	Test certificate
Measuring insert with ruby ball Ø 4 mm (TA-MI-101)	Hex screw driver 2 mm (TA-TO-002)
Setting gauge (TA-MG-101)	Hex screw wrench 5 mm (TA-TO-001)
Protection cover (TA-TO-109/110/111/112/113)	Touch screen pen (LABC-30.3)

CODE NUMBERS

Manual	Motorized	
VT300MA 700 107 10 01	VT300MO 700 107 10 02	Measuring range 300 mm
VT600MA 700 107 20 01	VT600MO 700 107 20 02	Measuring range 600 mm
VT1000MA 700 107 30 01	VT1000MO 700 107 30 02	Measuring range 1000 mm
VT1500MA 700 107 40 01		Measuring range 1500 mm
VT2000MA 700 107 50 01		Measuring range 2000 mm

VECTRA-TOUCH

APPLICATIONS

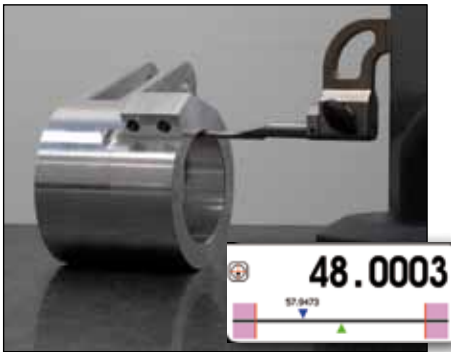

Diameter measurement with graphic help "EasyScan" (TA-MI-101/TA-AD-101)

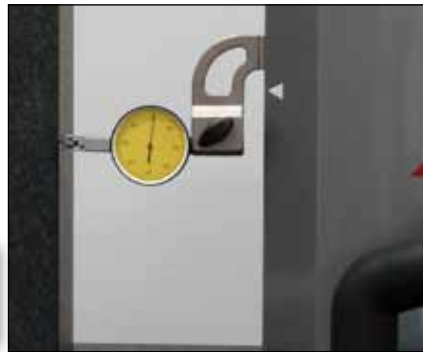

Squareness mechanically adjusted on all instruments

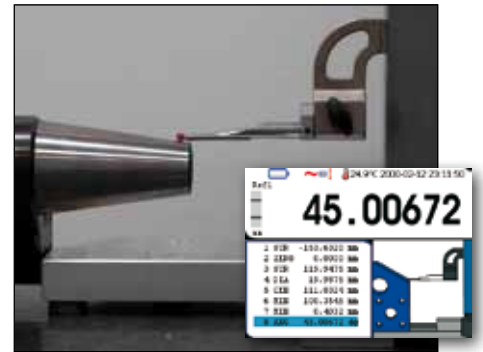

Measurement of angles and cones with graphic help display (TA-MI-101/TA-AD-101)

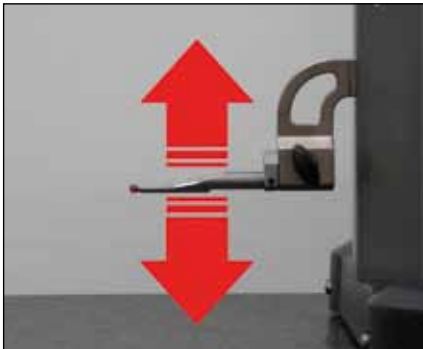

Measurement with automatic displacement in programming mode



Checking of squareness using an additional electronic probe and colour print-out of the curve (TA-MS-101)



Measurement using temperature compensation system with optional external sensor (TA-EL-120)



Storage of all data to an external memory, e.g. USB Memory Stick (TA-EL-140)



Wireless communication by Bluetooth or Wi-Fi (optional) (TA-EL-123/4)



Standard probes up to 320 mm. (here optional 550 mm)

MESTRA + TOUCH



MESTRA+TOUCH

INTRODUCTION

The "Mestra" height measuring instruments are classified among the most accurate ones worldwide. This new instrument line is the result of 40 years of experience, which makes it possible to offer a product having advanced technologies combined with ergonomic design.

The result of the well designed instrument concept incorporating an entire new measuring system is an optimum accuracy level. The extreme ease of use allows unrestricted application in production areas as well as in measuring laboratory environment.

Two specific models are available, "Mestra" and "Mestra-Touch". The difference between these two models is the layout of the display unit as well as the available measuring functions. The "Mestra" has a display unit incorporating all basic functions such as checking of heights, depths, diameters and centerline distances, squareness deviation, angles and tolerance limits indication. In addition the "Mestra-Touch" offers a colour touch screen and functions such as the 2-coordinate system, programming of measuring sequences, statistical analysis of memorized values and display of environmental temperature.

EXTREME ACCURACY LEVEL

GRAPHIC HELP FOR MEASURING

PRINTING OF REPORTS ON USB PRINTER

BACKUP ON EXTERNAL SUPPORT (USB KEY)

MEASURING RANGE FROM 300 MM TO 1000 MM















AVAILABLE IN MANUAL OR MOTORIZED VERSION

WORKING ON ACCUMULATOR





LARGE RANGE OF ACCESSORIES

DESCRIPTION

MESTRA + MESTRA-TOUCH

-  Surfaces
-  Internal/external diameters
-  Centerline distances
-  Graphic help "EasyScan"
-  Min/Max/Delta
-  9 references
-  Squareness measurements
-  Angle measurements
-  Calculation mode
-  Tolerances
-  USB ports
-  RS232 ports
-  Wireless communication
-  Automatic displacement

MESTRA-TOUCH

-  2D measuring mode
-  Measurement sequences
-  Statistical analysis
-  Temperature compensation
-  Online help



MESTRA + TOUCH

DISPLAY / SOFTWARE

The colour display facilitates the reading of all measuring parameters. The functions are easily and directly accessible.

INTERACTIVE HELP

DATE AND TIME DISPLAY

ACOUSTIC AND GRAPHIC PROBING INDICATOR

MEASURING OF VALUES WITH TOLERANCE INDICATION

GRAPHIC DISPLAY OF SQUARENESS

TOUCH SCREEN (MESTRA-TOUCH)

MEASURING IN 2D MODE (MESTRA-TOUCH)

MEASURING SEQUENCES (MESTRA-TOUCH)

STATISTICAL ANALYSIS (MESTRA-TOUCH)

TEMPERATURE COMPENSATION FEATURE
(MESTRA-TOUCH)

INTEGRATED ON LINE HELP (MESTRA-TOUCH)



Touch-screen with intuitive interface
(Mestra-Touch)



Easy identification of
each measuring function

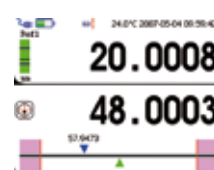

Graphical help for
diameter measurements



Clear indication of part
conformity

TECHNICAL SPECIFICATIONS

Mestra/Mestra-Touch		300	600	1000
Measuring range	mm (in)	305 (12)	610 (24)	1016 (40)
With second probe holder	mm (in)	567 (22)	872 (34)	1278 (50)
Max. permissible errors ¹⁾	µm	1.2+ L(mm)/1000		
Repeatability (2s) ¹⁾	µm	0.5 (Ø:1)		
Resolutions	mm (in)	0.01/0.001/0.0001 (.001/.0001/.00001)		
Manual carriage displacement speed	mm/s	1000		
Motorized carriage displacement speed	mm/s	150		
Measuring force (adjustable)	N	0.5 ÷ 1.8		
Frontal squareness deviation	µm	4	6	10
Autonomy	h	> 8		
Data output		2 x RS232 C and 2 x USB (A et B)		
Operational temperature	°C	+10 ÷ +40		
Temperature of storage	°C	-10 ÷ +40		
Weight	kg	22	25	29

¹⁾ Values valid with ball probe TA-MI-119 at temperature of 20 ± 0.5°C and relative humidity of 50 ± 5 %.

SCHEMA

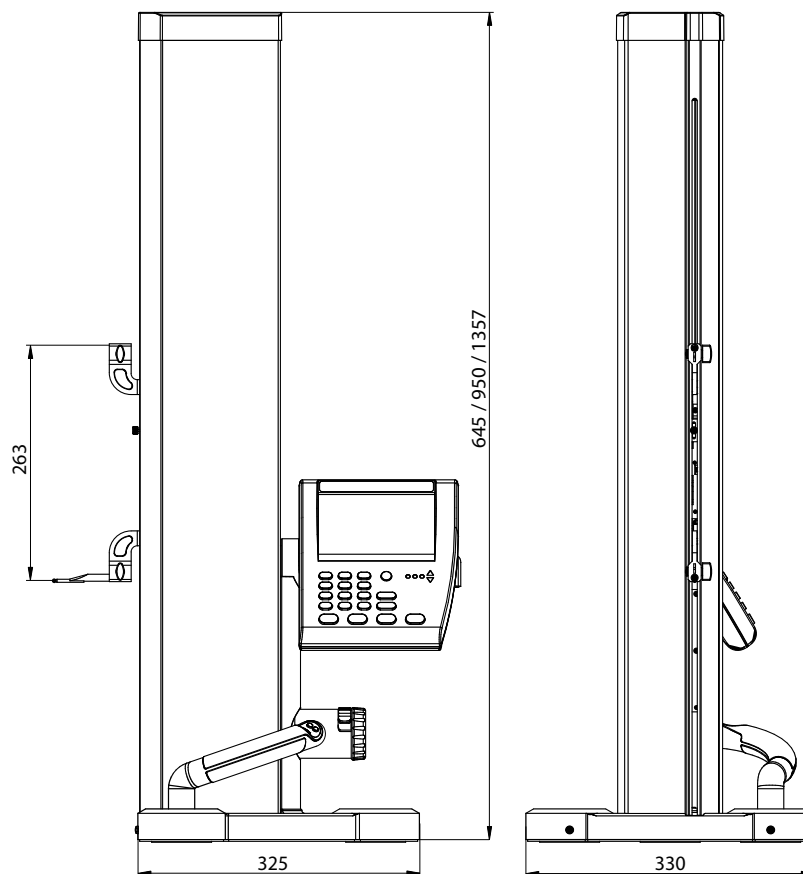

STANDARD INSTRUMENT

The Maestra and Maestra-Touch instruments are supplied as follows:

Instrument according to specifications	User's manual (750 50 0002 03)
Charging unit (TA-EL-130)	Test certificate
Measuring insert with ruby ball Ø 5 mm (TA-MI-119)	Hex screw driver 2 mm (TA-TO-002)
Setting gauge (TA-MG-101)	Hex screw wrench 5 mm (TA-TO-001)
Protection cover (TA-TO-109/110/111)	Touch screen pen (LABC-30.3)

CODE NUMBERS

Mestra		Mestra-Touch		
Manual	Motorized	Manual	Motorized	
M300MA 700 107 10 03	M300MO 700 107 10 04	MT300MA 700 107 10 05	MT300MO 700 107 10 06	Measuring range 300 mm
M600MA 700 107 20 03	M600MO 700 107 20 04	MT600MA 700 107 20 05	MT600MO 700 107 20 06	Measuring range 600 mm
M1000MA 700 107 30 03	M1000MO 700 107 30 04	MT1000MA 700 107 30 05	MT1000MO 700 107 30 06	Measuring range 1000 mm

MESTRA + TOUCH

APPLICATIONS



Height measurement of a small board (TA-IH-109/V-50.5/TA-MI-118)

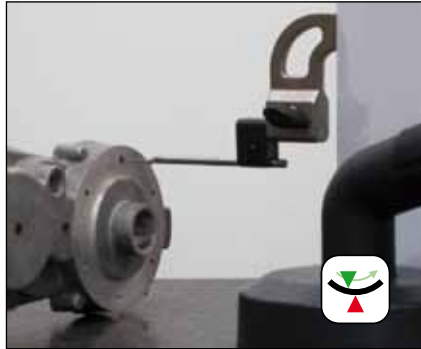

Checking of a small diameter using the adequate measuring insert (V-5/V-50.9)

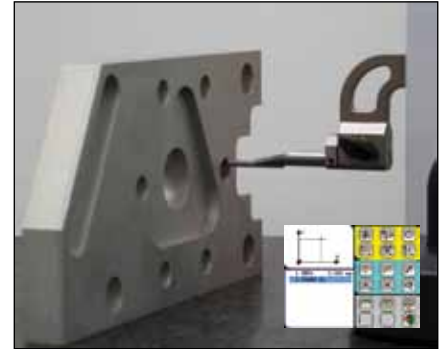

2-coordinate measurement with standard graphic help (TA-MI-101/TA-AD-101)

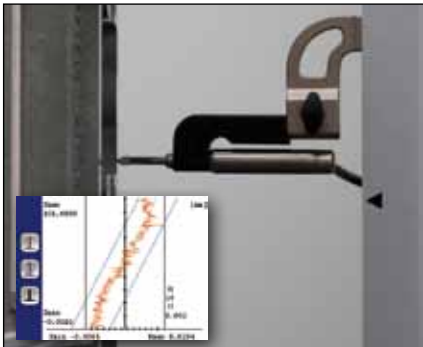

Checking of squareness deviation using an additional electronic probe and colour print-out of the curve (TA-MS-101)



Measurement of a groove using a 90° angled measuring insert holder and an L-shaped insert (TA-IH-105/V.50.5/V-50.3)

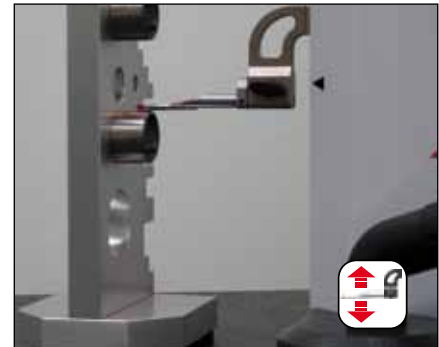

Automatic measurement of an external diameter performed with "TRIMOS® NC movement" (TA-MI-101/TA-AD-101)

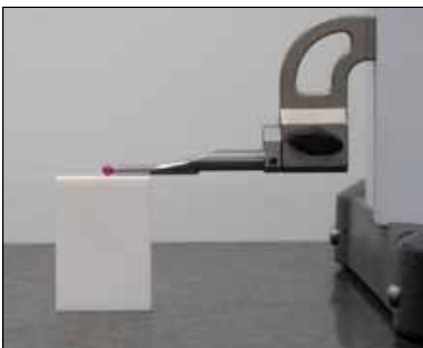

The complete digital measuring system offers an extremely high accuracy (TA-MI-101/TA-AD-101)



An USB data output allows the storage of all data on an USB Memory Stick as well as the printing of protocols (TA-EL-140)



Wireless communication by Bluetooth or Wi-Fi (optional) (TA-EL-123/4)

ACCESSORIES

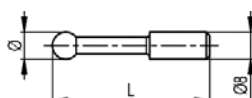
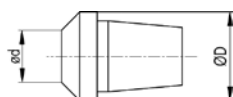

		TVM	V/V Plus	VT	M/MT
TV2S2 279 901007 010	Cone Ø 0-15 mm	•			
TV2S3 279 901007 003	Cone Ø 13-20.5 mm	•			
TV2S4 509 05 20 0001	Cone Ø 17-24.5 mm	•			
TV2S5 279 901007 005	Cone Ø 23-30.5 mm	•			
TV2S6 279 901007 006	Cone Ø 26-35.5 mm	•			
TV2S7 279 901007 007	Cone Ø 32-39 mm	•			
TV2S8 279 901007 008	Cone Ø 36-45 mm	•			
TV2S9 279 901007 009	Cone Ø 41-50 mm	•			
TV2S10 279 901007 010	Cone Ø 46-55 mm	•			
TV2S11 279 901007 011	Cone Ø 51-60 mm	•			
TVM2.9 509 05 20 0001	Ball insert Ø 0.5 mm	•			
TVM2.8 509 05 20 0003	Ball insert Ø 1 mm	•			
TVM2.4 509 05 20 0009	Ball insert Ø 2 mm	•			
TVM2.3 509 05 20 0014	Ball insert Ø 3 mm	•			
TVM2.2 509 05 20 0025	Ball insert Ø 4 mm	•			
TVM2.6 509 05 20 0031	Ball insert Ø 5 mm	•			
TVM2.1 509 05 20 0037	Ball insert Ø 6 mm	•			
TVM2.7 509 05 20 0045	Ball insert Ø 7 mm	•			
TVM2 509 05 20 0051	Ball insert Ø 8 mm	•			



TVM



V/V Plus



VT



M/MT

ACCESSORIES

			TVM	V/V Plus	VT	M/MT
	TVM2.5 509 05 20 0059	Disc shaped insert Ø 8 mm	●			
	TVM3 609 12 003	Scriber	●			
	TVM1003 609 12 002	Scriber for TVM1000	●			
	TV7.1 609 05 023	Knife-edge insert		●		
	TV7.2 609 05 022	Ball insert Ø 3 mm		●		
	TV7.3 609 05 020	Pin shaped insert Ø 2 mm		●		
	TV7.4 609 05 019	Disc shaped insert Ø 5 mm		●		
	TVA9.1 509 05 20 0011	barrel-shaped insert M3-M16		●	●	●
	TVA9.2 509 05 20 0029	barrel-shaped insert M6-M48		●	●	●
	TVA9.3 509 05 20 0062	barrel-shaped insert M12-M150		●	●	●
	TA-MI-111 509 05 20 0078	Measuring insert with tungst. carb. ball, Ø 1 mm		●	●	●
	TA-MI-110 509 05 20 0077	Measuring insert with tungst. carb. ball Ø 2 mm		●	●	●
	TA-MI-104 509 05 20 0080	Measuring insert with tungst. carb. ball Ø 2mm		●	●	●
	TA-MI-103 509 05 20 0076	Measuring insert with ruby ball Ø 2 mm		●	●	●

ACCESSORIES

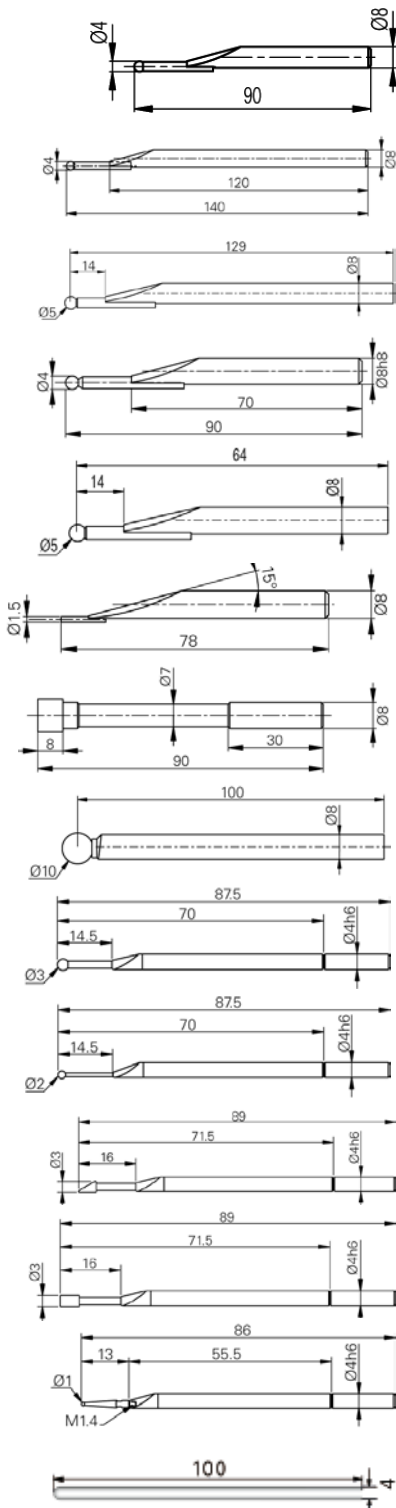

		TVM	V/V Plus	VT	M/MT
TA-MI-102 509 05 20 0075	Measuring insert with tungst. carb. ball \varnothing 4 mm		•	•	•
TA-MI-105 509 05 20 0079	Measuring insert with tungst. carb. ball \varnothing 4 mm		•	•	•
TA-MI-106 279 918011 004	Measuring insert with ruby ball \varnothing 5 mm		•	•	•
TA-MI-101 509 05 20 0074	Measuring insert with ruby ball \varnothing 4 mm		•	•	
TA-MI-119 SP279 918011 005	Measuring insert with ruby ball \varnothing 5 mm				•
TA-MI-107 509 05 20 0081	Measuring insert with pin \varnothing 1.5 mm		•	•	•
TA-MI-112 509 05 20 0082	Measuring insert with parallel faces		•	•	•
TA-MI-108 279 918011 002	Measuring insert with ruby ball \varnothing 10 mm		•	•	•
TA-MI-109 279 918011 003	Measuring insert with ruby ball \varnothing 3 mm		•	•	•
V-50.9 279 918011 001	Measuring insert with ruby ball \varnothing 2 mm		•	•	•
V-50.10 279 918007 001	Knife-edge insert		•	•	•
V-50.11 279 918013 001	barrel-shaped insert \varnothing 3 x 5 mm		•	•	•
V-50.12 279 918012 001	Measuring insert \varnothing 1 mm with holder		•	•	•
TA-MI-114 506 22 20 0063	Pin, 1 hemispheric and 1 plane face		•	•	•



TVM



V/V Plus





VT





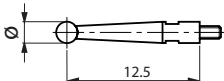
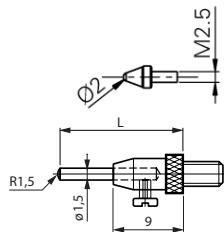
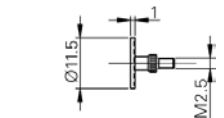
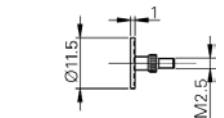
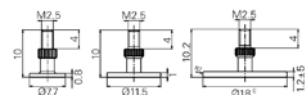
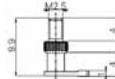
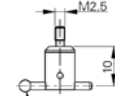

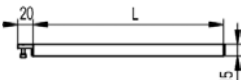

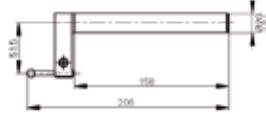
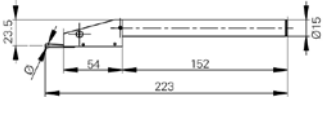

M/MT

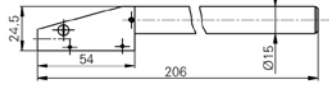
ACCESSORIES

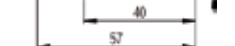
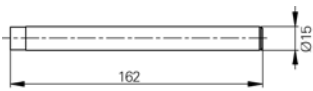
		TVM	V/V Plus	VT	M/MT
	<p>TA-MI-115 279 901001 001</p> <p>Measuring insert M1.4 with ball \varnothing 1 mm</p>		•	•	•
	<p>TA-MI-116 279 901001 002</p> <p>Measuring insert M1.4 with ball \varnothing 2 mm</p>		•	•	•
	<p>TA-MI-117 279 901001 003</p> <p>Measuring insert M1.4 with ball \varnothing 3 mm</p>		•	•	•
	<p>V-50.4 279 918010 001</p> <p>Measuring insert M2,5 with ball contact</p>		•	•	•
	<p>TA-MI-118 279 901003 001</p> <p>Measuring insert M2.5 with 4 interchangeable pins L=16/26/36/46 mm</p>		•	•	•
	<p>V-50.2.1 279 918005 002</p> <p>Disc-shaped inserts M2.5, \varnothing 7.7 mm</p>		•	•	•
	<p>V-50.2.2 279 918005 003</p> <p>Disc-shaped inserts M2.5, \varnothing 11.5 mm</p>		•	•	•
	<p>V-50.2.3 279 918005 004</p> <p>Disc-shaped inserts M2.5, \varnothing 18 mm</p>		•	•	•
	<p>V-50.2 279 918005 001</p> <p>Set of 3 disc-shaped inserts M2.5</p>		•	•	•
	<p>V-50.3 279 918008 001</p> <p>Corner insert M2.5</p>		•	•	•
	<p>V-50.1 279 918009 001</p> <p>Measuring insert M2.5 with ruby ball \varnothing 3 mm</p>		•	•	•
	<p>TVM1.1 502 02 10 0015</p> <p>Clamping device \varnothing 8 mm</p>	•			
	<p>TVM1 612 11 007</p> <p>Standard insert holder for TVM, L=154 mm</p>	•			
	<p>TVM1/L250 612 11 061</p> <p>Insert holder, L=250 mm</p>	•			
	<p>TVM1/L300 612 11 062</p> <p>Insert holder, L=300 mm</p>	•			
	<p>TVM1/L350 612 11 063</p> <p>Insert holder, L=350 mm</p>	•			

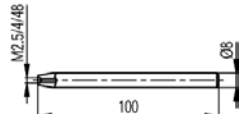
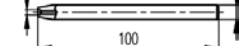
ACCESSORIES

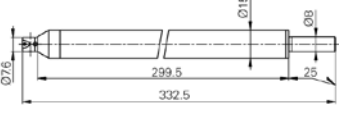
			TVM	V/V Plus	VT	M/MT
	TVM1/1.1/2 609 05 061	Measuring insert + holder (TVM1 + 1.1 + 2)	•			
	TVA1 612 11 028	Measuring insert + holder for TVM1000	•			
	TVM4 609 05 074	Bi-directional probe Ø4 mm	•			
	TVM4.1/4.2 609 05 075	Bi-directional probe Ø2 mm	•			
	TVM4.1 612 11 030	Support pour touche bidirectionnelle	•			
	TVM4.2 609 05 021	Measuring insert Ø2 mm for bi-directional probe	•			
	TVM4.3 609 05 024	Measuring insert Ø4 mm for bi-directional probe	•			
	TVM5.1 609 05 054	Cone holder	•			
	TVM5 709 05 054	Set of cones with holder (TV2S2/3/4/5 + TVMS2)	•			
	TVM6 512 11 20 0018	Holder Ø8 mm for measuring inserts M2.5	•			
	TVM6E 512 11 20 0019	Holder Ø8 mm for measuring inserts 4-48	•			
	TA-IH-101 612 11 045	Measuring insert holder M2.5		•	•	•
	TA-IH-103 612 11 047	Measuring insert holder 4-48		•	•	•
	TA-IH-102 612 11 046	Measuring insert holder M2.5		•	•	•



TVM



V/V Plus











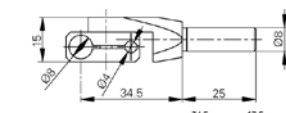
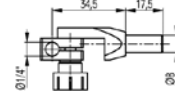

VT



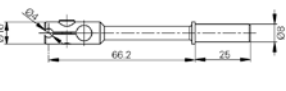

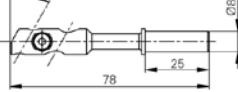
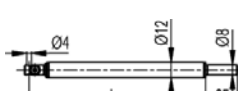
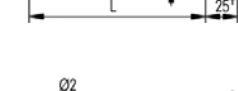
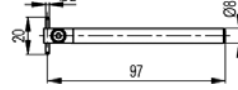
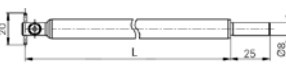

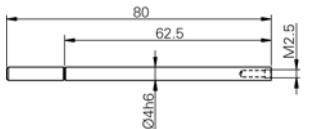
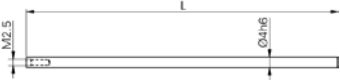
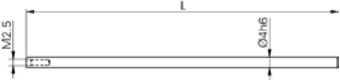
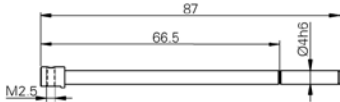
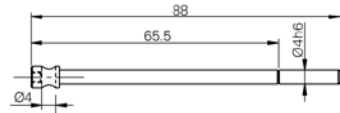
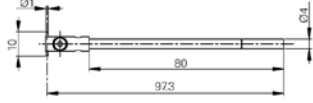
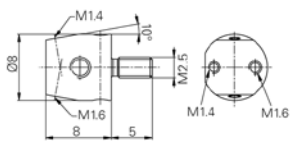
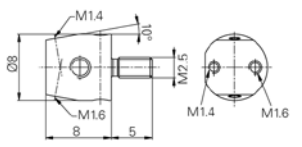
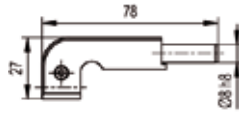

M/MT

ACCESSORIES

		TVM	V/V Plus	VT	M/MT
 <p>TA-IH-104 612 11 053</p>	Swivel holder \varnothing 4 and 8 mm		•	•	•
 <p>V-2E 612 11 023</p>	Swivel holder \varnothing 1/4 "		•		
 <p>TA-IH-105 612 11 051</p>	Swivel holder \varnothing 4 and 8 mm		•	•	•
 <p>V-2E/D1/4/L150 612 11 013</p>	Swivel holder \varnothing 1/4"		•	•	•
 <p>TA-IH-106 612 11 039</p>	Swivel holder \varnothing 4 and 8 mm		•	•	•
 <p>TA-IH-107 612 11 055</p>	Insert holder 90°, \varnothing 8 mm		•	•	•
 <p>TA-IH-108 612 11 052</p>	Insert holder 90°, \varnothing 8 mm		•	•	•
 <p>TA-IH-109 612 11 054</p>	Insert holder 90°, \varnothing 4 mm		•	•	•
 <p>TA-IH-110 279 918103 001</p>	Insert holder 90°, \varnothing 4 mm		•	•	•
 <p>V-4 612 11 011</p>	Insert holder 30°, \varnothing 4 mm		•	•	•
 <p>TA-IH-111 612 11 041</p>	Insert holder 90°, \varnothing 4 mm, L=150 mm		•	•	•
 <p>TA-IH-112 612 11 042</p>	Insert holder 90°, \varnothing 4 mm, L=300 mm		•	•	•
 <p>TVA4 609 05 007</p>	Insert holder with pin \varnothing 2 x 20 mm		•	•	•
 <p>TA-IH-113 612 11 043</p>	Insert holder with pin \varnothing 2 x 20 mm, L=200 mm		•	•	•
 <p>TA-IH-114 612 11 044</p>	Insert holder with pin \varnothing 2 x 20 mm, L=300 mm		•	•	•

ACCESSORIES

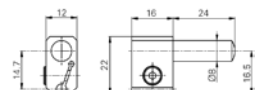
			TVM	V/V Plus	VT	M/MT
	V-50.6 279 918002 002	Measuring insert holder M2.5		•	•	•
	V-50.5 279 918002 001	Measuring insert holder M2.5, L=124 mm		•	•	•
	TA-IH-115 279 918002 003	Measuring insert holder M2.5, L=200 mm		•	•	•
	V-50.7 279 918001 002	Insert holder 90°, M2.5		•	•	•
	V-50.8 279 918001 001	Insert holder 90°, Ø 4 mm		•	•	•
	TA-IH-116 279 918001 003	Measuring insert holder Ø 1 x 10 mm		•	•	•
	TA-IH-117 512 11 20 0012	Holder for measuring inserts M2.5, M1.6, M1.4		•	•	•
	TA-IH-118 512 11 20 0013	Holder for measuring inserts 4-48, M1.6, M1.4		•	•	•
	TA-IH-126 612 07 006	Holder for squareness probe			•	•
	TA-MS-101 276 940001 001	Squareness probe for VT/M/MT 300/600			•	•
	TA-MS-102 276 940001 002	Squareness probe for VT/M/MT 1000			•	•
	TA-MS-103 609 02 020	Squareness probe for VT1500			•	
	TA-MS-104 609 02 021	Squareness probe for VT2000			•	
	TVM1010 603 12 005	Reduction sleeve Ø 20 / 15 mm (TVM1000)	•			
	V-5 612 11 012	Reduction Ø 8 / 4 mm		•	•	•



TVM



V/V Plus



VT





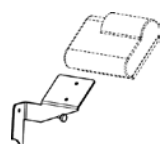
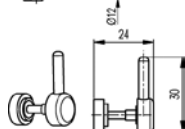
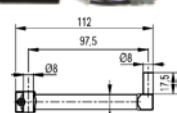
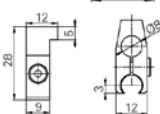
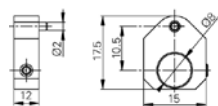

M/MT

ACCESSORIES



		TVM	V/V Plus	VT	M/MT
TA-AD-101 603 11 001	Positioning holder for measuring insert VT/MT			●	●
TA-AD-102 603 11 002	Positioning holder for measuring insert V+		●		
TA-AD-104 SP612 05 014 01	Mobile support for display VT/MT			●	●
V-7/H100 612 11 025	Extension for probe holder 100 mm		●		
V-20 606 00 029	Quick clamp for insert holder		●		
V-32 612 06 001	Printer holder for V+		●		
V-32/SP SP612 06 001 01	Printer holder for VT/MT (factory mounted only)			●	●
TA-SE-101 605 01 007	Set of accessories "Macro" (16 pcs)		●	●	●
TA-SE-102 605 01 008	Set of accessories "Micro" (20 pcs)		●	●	●
TA-MG-103 609 01 026	Setting gauge		●		
TA-MG-101 609 01 024	Setting gauge 25 mm			●	●
TA-MG-102 609 01 025	Setting gauge 1"			●	●
V-60 612 12 045	Wooden accessories support		●	●	●
V-50.13 290 918001 001	Wrench for measuring inserts		●	●	●

ACCESSORIES

			TVM	V/V Plus	VT	M/MT
	V-50.15 290 000911 005	Allen key 2.5 mm		•		
	TA-TO-001 290 000911 009	Allen key 5 mm			•	•
	TA-TO-002 290 920001 001	Hex Screwdriver 2 mm		•	•	•
	LABC-30.3 3708 0002	Touch screen pen			•	•
	TVM.HO300 505 05 10 0009	Protection cover for TVM301, TC401	•			
	TVM.HO600 505 05 10 0011	Protection cover for TVM601, TC601	•			
	TVM.HO1000 505 05 10 0013	Protection cover for TVM1000	•			
	V.HO300 505 05 10 0020	Protection cover for V300		•		
	V.HO600 505 05 10 0021	Protection cover for V600		•		
	V.HO1000 505 05 10 0022	Protection cover for V1000		•		
	TA-TO-109 505 05 10 0005	Protection cover for VT/M/MT 300			•	•
	TA-TO-110 505 05 10 0006	Protection cover for VT/M/MT 600			•	•
	TA-TO-111 505 05 10 0007	Protection cover for VT/M/MT 1000			•	•
	TA-TO-112 505 05 10 0008	Protection cover for VT 1500			•	
TA-TO-113 505 05 10 0037	Protection cover for VT 2000			•		



TVM



V/V Plus



VT



M/MT

ACCESSORIES

			TVM	V/V Plus	VT	M/MT
	BAT-TVM.OPTO 3705 0002	Battery	●			
	TELMA31 3706 0002	Foot pedal		●		
	TA-EL-101 3706 0006	Foot pedal (VT/MT)			●	●
	LABC-40 356 0010	Laser printer (USB)			●	●
	TA-EL-030 356 0016	Inkjet printer (USB)			●	●
	V-30 356 0007	Printer (RS232)		●	●	●
	TVM.O-PC/AT.9P 333 9 0003	Cable Opto-PC / AT 9 P/F 2 m	●			
	V-31 333 0 0003	Cable for RS232 printer		●		
	CABL.RS.1/1-9P 332 01 0001	Cable RS232 m/f, 1.8 m (VT/M/MT: Printer & V / V Plus / H: PC)		●	●	●
	TA-EL-110 332 01 0012	Cable RS232 f/f, 1.8 m (PC)			●	●
	TA-EL-013 332 02 0001	USB A-B connection cable, L=1.8 m			●	●
	TA-EL-011 358 0006	USB-RS232 Converter	●	●	●	●
	TA-EL-131 334 0020	Universal AC adapter, 9 V (without cable)		●		

ACCESSORIES

			TVM	V/V Plus	VT	M/MT
	TA-EL-130 357 0100	Universal AC adapter, 28 V (without cable)			•	•
	TA-EL-001 332 10 0011	Power cable, 2 poles, Europe		•	•	•
	TA-EL-002 332 10 0013	Power cable, 2 poles, USA/Japan		•	•	•
	TA-EL-003 332 10 0016	Power cable, 2 poles, Australia		•	•	•
	TA-EL-004 332 10 0014	Power cable, 2 poles, UK		•	•	•
	TA-EL-005 616 20 003	Power cable, 2 poles, Korea		•	•	•
	V-30.7 788 000001 001	Paper rolls (5 pcs)		•		
	TA-EL-120 609 50 005	Temperature compensation system			•	
	TA-EL-121 616 70 001	Wireless communication system "Wi-Fi"			•	•
	TA-EL-122 616 70 002	Wireless communication system "Bluetooth"			•	•
	TA-EL-123 609 50 006	Temperature compensation system "Wi-Fi"			•	
	TA-EL-124 609 50 007	Temperature compensation system "Bluetooth"			•	
	TA-EL-140 358 0008	USB memory stick			•	•
	TA-SW-001 394 1 0050	Software for data transfer WinDDE	•	•	•	•



TVM



V/V Plus



VT



M/MT

ACCESSORIES



TA-SE-101
605 01 007

Set of accessories Macro (16 pieces):

- TA-MI-105** Measuring insert with tungst. carb. ball Ø4 mm, L=140 mm
- TA-MI-110** Measuring insert with tungst. carb. ball Ø2 mm, L=80 mm
- TA-MI-107** Measuring insert with pin Ø1.5 mm, L=78 mm
- TA-IH-105** Swivel holder Ø4 and Ø8 mm, L=150 mm
- TA-IH-109** Insert holder 90°, Ø4 mm
- TVA4** Insert holder with pin Ø2 x 20 mm
- TA-IH-101** Measuring insert holder M2.5, L=103 mm
- V-50.5** Measuring insert holder M2.5, L=124 mm
- TA-IH-115** Measuring insert holder M2.5, L=200 mm
- V-50.4** Measuring insert M2,5 with ball contact
- V-50.2.3** Disc-shaped inserts M2.5, Ø18 mm
- TA-MI-115** Measuring insert M1.4 with ball Ø1 mm, L=12.5 mm
- TA-MI-116** Measuring insert M1.4 with ball Ø2 mm, L=12.5 mm
- TA-MI-117** Measuring insert M1.4 with ball Ø3 mm, L=12.5 mm
- V-50.13** Wrench for measuring inserts
- V-50.15** Allen key 2.5 mm

TVM
V/V Plus
VT
M/MT

• • •



TA-SE-102
605 01 008

Set of accessories Micro (20 pieces):

- V-50.4** Measuring insert M2,5 with ball contact
- TA-MI-118** Measuring insert M2.5 with 4 interchangeable pins
- V-50.2.1** Disc-shaped inserts M2.5, Ø7.7 mm
- V-50.2.2** Disc-shaped insert M2.5, Ø11.5 mm
- V-50.3** Corner insert M2.5
- TA-MI-115** Measuring insert M1.4 with ball Ø1 mm, L=12.5 mm
- TA-MI-116** Measuring insert M1.4 with ball Ø2 mm, L=12.5 mm
- TA-MI-117** Measuring insert M1.4 with ball Ø3 mm, L=12.5 mm
- TA-IH-117** Holder for measuring inserts M2.5, M1.6, M1.4
- V-50.6** Measuring insert holder M2.5
- V-50.8** Insert holder 90°, Ø4 mm
- TA-IH-116** Measuring insert holder, Ø1 x 10 mm, L=80 mm
- V-50.9** Measuring insert with ruby ball Ø2 mm, L=88 mm
- V-50.12** Measuring insert Ø1 mm with holder, L=86 mm
- V-50.10** Knife-edge insert
- V-5** Reduction Ø 8 / 4 mm
- TA-IH-104** Swivel holder Ø4 and Ø8 mm
- V-50.13** Wrench for measuring inserts
- TA-TO-003** Allen key 1.5 mm
- V-50.15** Allen key 2.5 mm

• • •

TELS



TELS

INTRODUCTION

The Mini-Horizontal TELS is the ideal instrument for checking small dimensions. It is part of the horizontal instruments family.

The instrument is mainly used for checking internal and external dimensions, such as ring gauges, plug gauges, thread plug gauges and for measuring precision production parts.

The reliable concept is easily suitable for the use in workshop environment.

An electronic probe and digital display unit or simply a dial indicator can be applied to perform all measurements. The selection of the measuring system depends on the required accuracy.

The range for internal measurements from 10 to 100 mm and external measurements from 0 to 100 mm covers a large number of applications. The absolute measuring range is 25 mm and a preset setting is necessary to obtain an entire length.

A wide range of accessories are available.

IDEAL FOR CHECKING SMALL DIMENSIONS

EASY MANIPULATION

SUITABLE FOR USE IN WORKSHOP AREA

WIDE SELECTION OF ACCESSORIES

DESCRIPTION

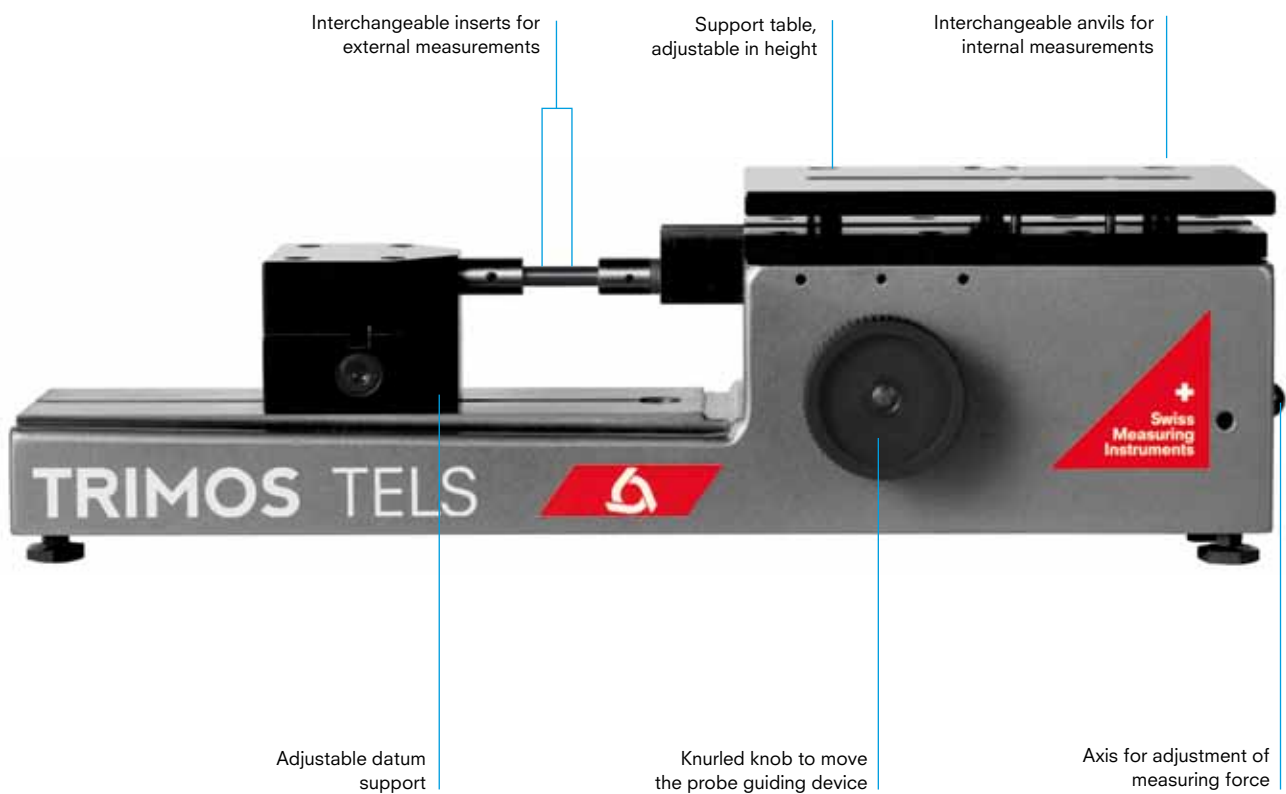

SCHEMA

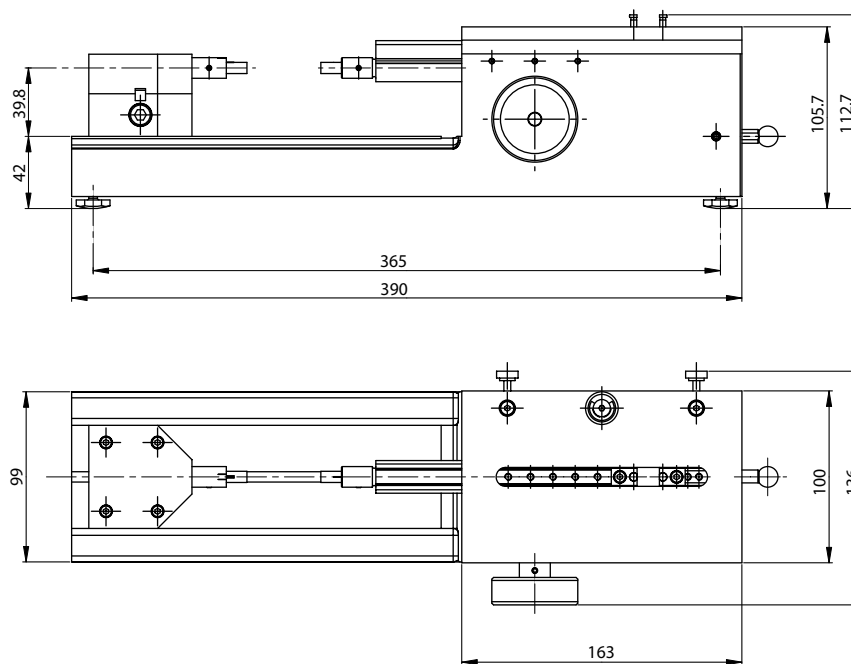

STANDARD INSTRUMENT

The TELS instruments are supplied as follows:

Instrument according to specifications	User's manual (750 50 0019 03)
Measuring inserts for external measurement (TELS50)	Lapping plate (TA-TO-301)
Measuring anvils for internal measurements (TELS10)	Test certificate

CODE NUMBERS

TELS

TELS 700 205 00 01

TELS

APPLICATIONS



Checking of external diameters
(TELS50, TELS5, TELS5.1)



Checking of internal diameters
(TELS10)



Checking of internal grooves
(TELS10)



Checking of lengths
(TELS50, TELS5, TELS5.1)

ALESTA



ALESTA

INTRODUCTION

The Alesta family is a product that simplifies the setting of 2-point bore gauges. It replaces the traditional way using a lot of different rings.

Thanks to innovative adapters, a positioning error will be eliminated and the speed of measurements increased. You just input the dimension into the key board and the required mobile carriage will position itself automatically onto this position. The mobile carriage system will always stay in the desired position even when applying a force on the anvils.

The stable granite base combined with a high precision measuring system guarantees excellent measuring results. Using a tolerance table the carriage can be positioned to the selected tolerance range. This table can be tailor-made to customer's requirements. This product achieves a typical return on investment of 2 years. The acquisition of new rings and their calibration will be eliminated. The instrument range includes 3 models: 300, 500 and 1000 mm.

IDEAL FOR USE IN THE WORKSHOP AREA

VERY SIMPLE MANIPULATION

MOTORIZED CARRIAGE MOVEMENT

STABLE GRANITE BASE

HIGH PRECISION MEASURING SYSTEM (HEIDENHAIN)

TOLERANCE DATA BASE

WIDE SELECTION OF ADAPTERS AND ACCESSORIES

INTERNAL AND EXTERNAL MEASUREMENT POSSIBLE

DESCRIPTION



ALESTA

DISPLAY / SOFTWARE

PROGRAMMING OF 100 TOLERANCED DIMENSIONS

MANUAL OR AUTOMATIC DISPLACEMENT

PROGRAM IN ITALIAN, ENGLISH, FRENCH, PORTUGUESE, GERMAN, SPANISH

INTERNAL AND EXTERNAL MEASUREMENT

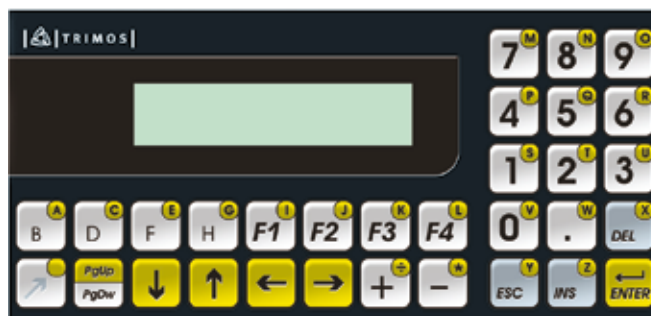

TECHNICAL SPECIFICATIONS

Alesta		300	500	1000
Application range (external measurements)	mm (in)	300 (12)	500 (20)	1000 (40)
Application range (internal measurements)	mm (in)	40 ÷ 340 (1.6 ÷ 13.5)	40 ÷ 540 (1.6 ÷ 21.5)	40 ÷ 1040 (1.6 ÷ 41)
Max. permissible errors ¹⁾	µm	1.5 + L(mm) / 300		
Repeatability (2s) ¹⁾	µm	< 1		
Resolutions	mm (in)	0.001 (.00001)		
Holding force	N	240		
Interfaces		RS232 et USB		
Operational temperature	°C	+10 ÷ +40		
Temperature of storage	°C	-10 ÷ +40		
Weight	Kg	62	77	200

¹⁾ Values valid at temperature of 20 ± 0.2 °C and relative humidity of 50 ± 5%.

SCHEMA

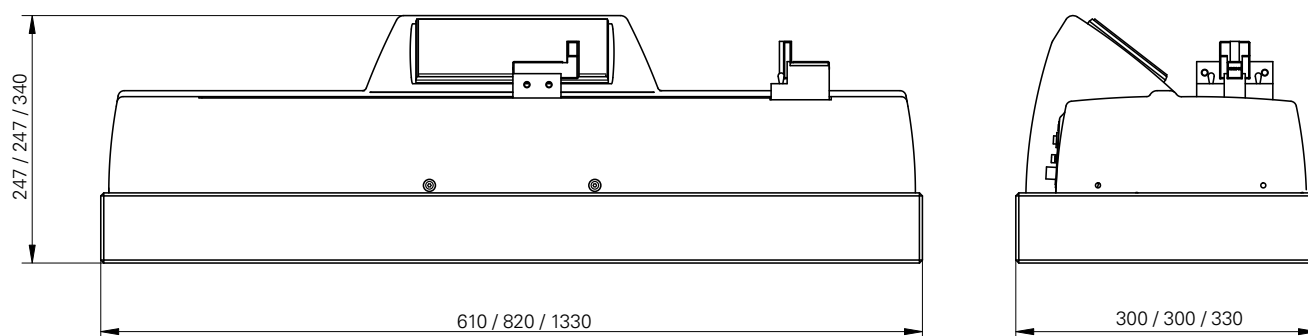

STANDARD INSTRUMENT

The Alesta instruments are supplied as follows:

Instrument according to specifications	User's manual (750 50 0022 00)
	Test certificate

CODE NUMBERS

Alesta	
ALE300P 700 204 00 02	Measuring range 300 mm
ALE500P 700 204 10 02	Measuring range 500 mm
ALE1000P 700 204 20 02	Measuring range 1000 mm

ALESTA

APPLICATIONS



Setting of two-point bore gauges



No need to have a lot of different setting rings. They are replaced by one single instrument



Checking of calipers

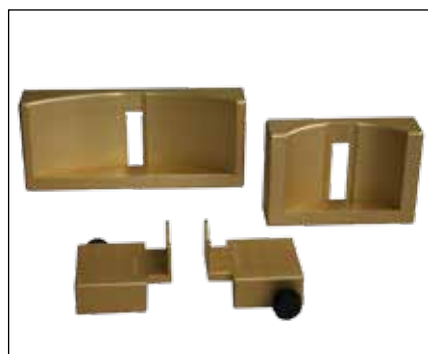

Wide range of adapters to fit most two-point bore gauges and guarantee of easy/quick setting



Quick positioning using pre-programmed data

HORIZON + Granite



HORIZON + Granite

INTRODUCTION

The «Horizon» instruments respond to the current requirements for quality inspection in manufacturing areas. They allow a quick, precise checking and setting.

The instruments are perfect for setting all kinds of comparative measuring equipment and for checking length, internal and external diameters, thread gauges etc.

The new innovative concept with incorporated measuring system and display unit ensures excellent results by easy manipulation and is the answer to various demands in the field of production. Simplicity of use is an additional valuable advantage.

The instrument range comprises several models, from 500 mm up to 2000 mm (Granite 3000 - 8000 mm). A wide selection of easy interchangeable accessories completes the application possibilities.

IDEAL FOR USE IN THE WORKSHOP AREA

VERY SIMPLE MANIPULATION

PRECISE CHECKING AND SETTING MADE EASY

SELF-CONTAINED OPERATION OF APPROX. 100 HOURS

WIDE SELECTION OF ACCESSORIES

DESCRIPTION

HORIZON

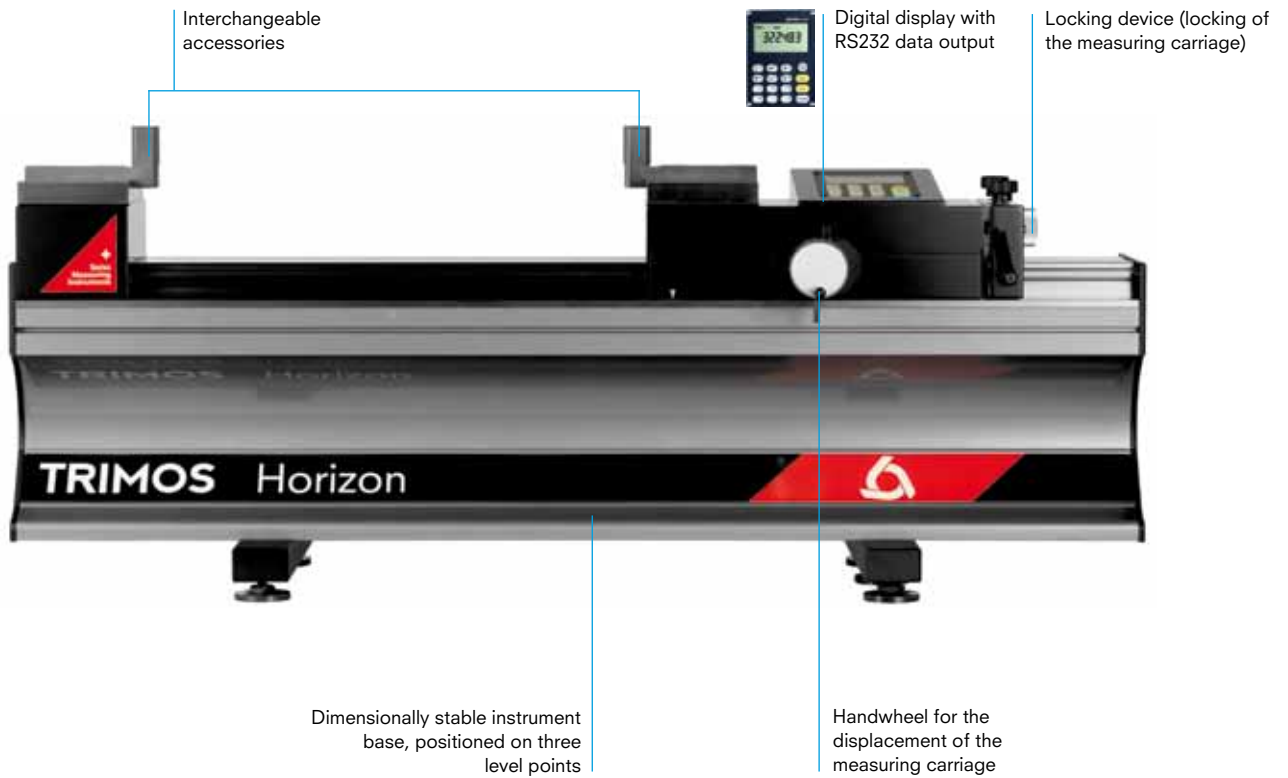

HORIZON GRANITE



HORIZON + Granite

DISPLAY / SOFTWARE

HORIZON

- SELECTION OF VALUE: NORMAL / MIN / MAX

- ZERO SETTING OF THE DISPLAY AND PRESET INPUT

- RS232 DATA OUTPUT

- TWO REFERENCES

- SELECTION OF THE RESOLUTION 0.01 MM - 0.001 MM

- SELECTION OF MEASURING UNIT MM / INCH (DIRECT CONVERSION)



sylvac system



HORIZON GRANITE

Heidenhain ND287 or ND1100

- LINEAR MEASUREMENT DISPLAY AND MIN. / MAX. VALUE HOLD

- DIGITAL DISPLAY

- ZERO SETTING OF THE DISPLAY AND PRESET INPUT

- PARAMETER SETTINGS

- INITIALIZATION OF THE DISPLAY USING EXTERNAL FUNCTION

- RS232 DATA OUTPUT



Heidenhain ND287



Heidenhain ND1100



PC with software WinDHI

- GRAPHIC HELP FOR MEASURING FUNCTIONS

- SELECTION OF THE MEASURING UNIT MM / INCH

- DIRECT DISPLAY OF ALL LENGTH MEASURING VALUES AND MIN. / MAX. VALUE HOLD

- INPUT OF 9 PRESET VALUES

- INVERSION OF MEASURING DIRECTION SIGN (+/-)

- DATA TRANSFER USING A FOOT PEDAL



TECHNICAL SPECIFICATIONS

Horizon		H501	H1001	H1501	H2001
Measuring range	mm (in)	520 (20)	1020 (40)	1520 (60)	2020 (80)
Max. permissible errors ¹⁾	µm	2.5 + L/300			
Repeatability (2s) ¹⁾	µm	1			
Resolutions	mm (in)	0.01/0.001 (.0001 / .00005)			
Max. displacement speed	mm / s	1500			
Measuring force	N	3			
Autonomy	h	100			
Interface		RS232			
Operational temperature	°C	+10 ÷ +40			
Temperature of storage	°C	-10 ÷ +40			
Weight	Kg	94	126	158	190

¹⁾ Values valid at temperature of 20 ± 0.2 °C and relative humidity of 50 ± 5%.

Horizon Granite		HG3000	HG4000	HG5000	HG6000	HG8000
Measuring range	mm (in)	3000 (118)	4000 (157)	5000 (196)	6000 (236)	8000 (315)
Max. permissible errors ¹⁾	µm	0.7 + L/750				
Repeatability (2s) ¹⁾	µm	0.5				
Resolutions	mm (in)	0.01 / 0.001 / 0.0001 (.001 / .0001 / .00001)				
Max. displacement speed	mm / s	2000				
Measuring force	N	3				
Interfaces		RS232/USB				
Operational temperature	°C	+10 ÷ +40				
Temperature of storage	°C	-10 ÷ +40				
Relative humidity	%	20 ÷ 80				
Weight	Kg	1060	1980	3200	3700	4600

¹⁾ Values valid at temperature of 20 ± 0.2 °C and relative humidity of 50 ± 5%.

HORIZON + Granite

SCHEMA

HORIZON

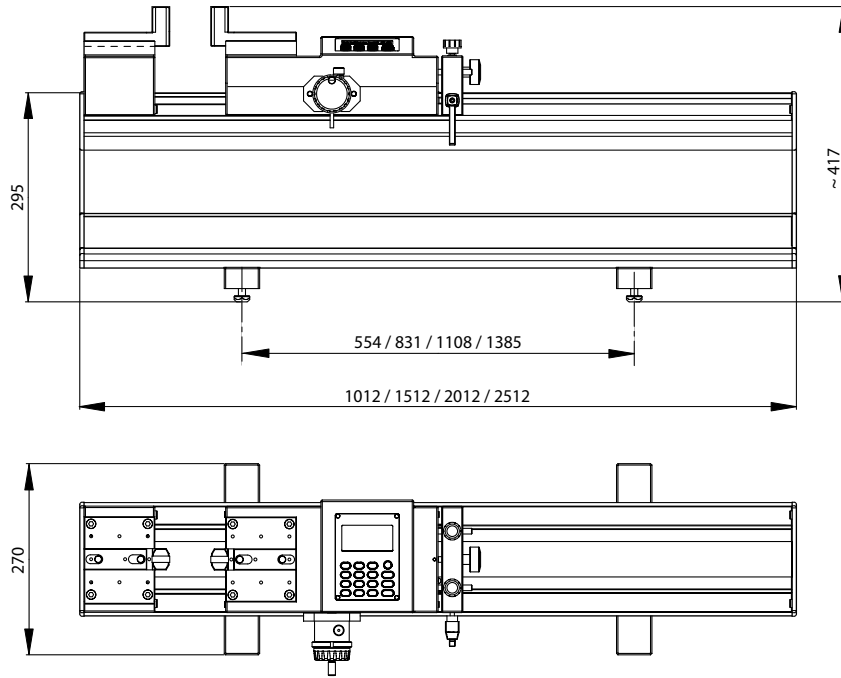

HORIZON GRANITE

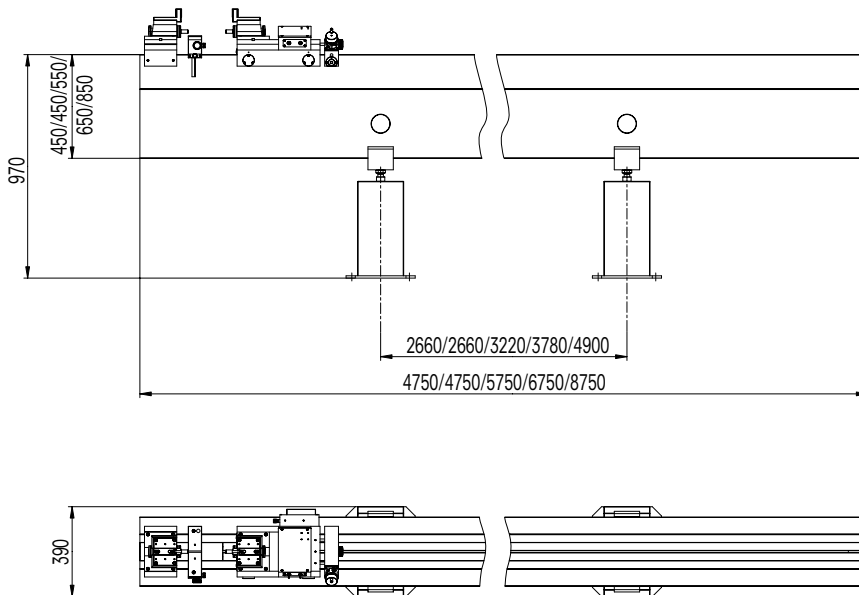

STANDARD INSTRUMENT

The Horizon instruments are supplied as follows:

Instrument according to specifications
Pair of parallel attachments 25 mm (TEL5)
Universal AC adapter (TA-EL-131)
Protection cover (TEL.HO500/1000/1500/2000)
Allen key set (TA-TO-004)
User's manual (750 50 0005 03)
Test certificate

The Horizon Granite instruments are supplied as follows:

Instrument according to specifications
Pair of anvils with tungsten carbide surface (TEL1)
Lapping plate (TA-TO-302)
Protection cover (TEL.HO3000/4000/5000/6000/8000)
Compressed air tubing and air filter
Allen key set (TA-TO-004)
User's manual (750 50 0003 03)
Test certificate

CODE NUMBERS

Horizon		
H501	700 201 10 02	Measuring range 500 mm
H1001	700 201 20 02	Measuring range 1000 mm
H1501	700 201 30 02	Measuring range 1500 mm
H2001	700 201 40 02	Measuring range 2000 mm

Horizon Granite		
HG3000	700 208 60 11	Measuring range 3000 mm
HG4000	700 208 70 11	Measuring range 4000 mm
HG5000	700 208 80 11	Measuring range 5000 mm
HG6000	700 208 90 11	Measuring range 6000 mm
HG8000	700 208 110 11	Measuring range 8000 mm

HORIZON + Granite

APPLICATIONS

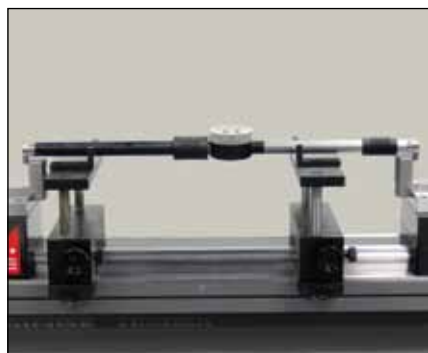

Setting of 2-point internal and external comparative measuring equipment (TEL5/TELMA7/TELMN7.2)



Setting of 2-point bore gauges (TEL5/TA-SU-301)

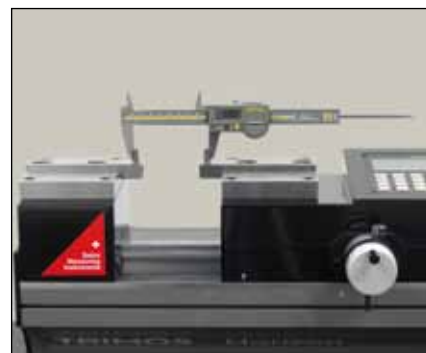

Checking of calipers (TEL5.10)

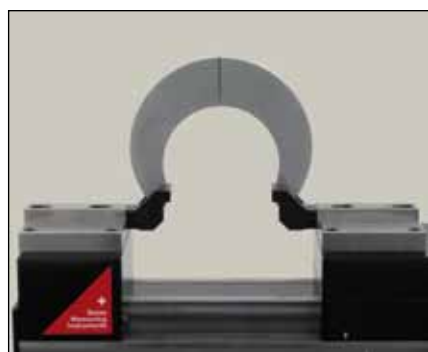

Checking of snap gauges (TELMA8)

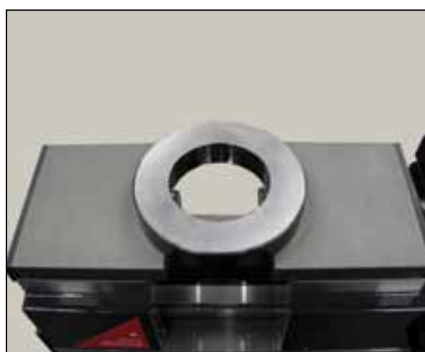

Checking of internal diameter of heavy rings (TEL9/H-5)



Checking of depth gauges (TULM19/TEL5)



Checking of external micrometers (TEL5/TEL11)

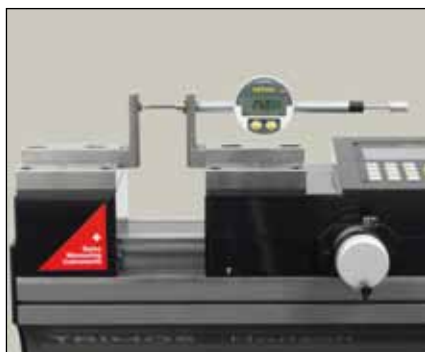

Checking of dial indicators (TEL5CN)

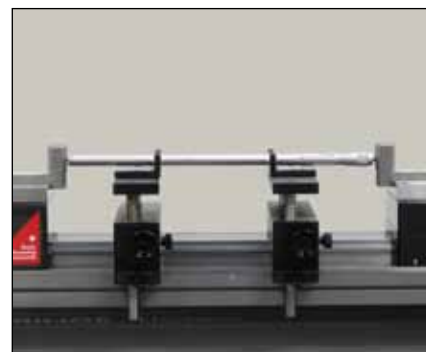

Checking of 2-point internal micrometers (TEL5/TELMA7/TELMN7.2)

HORIZON PREMIUM



HORIZON PREMIUM

INTRODUCTION

The HORIZON PREMIUM instruments fulfill today's requirements of high accuracy quality control equipment in production areas and take into consideration EN ISO 9000 standards.

The instruments may be used in a workshop area or installed in a quality control room for checking of measuring gauges and setting of all types of comparative measuring equipment. The well-designed, reliable new concept, obtained by superior engineering, ensures high precision and optimum results by easy manipulation as well as a valuable level of productivity.

The modular design allows the selection between two measuring systems: analog signal output and Heidenhain display unit or digital signal output and computer with TFT touch screen and Trimos-WinDHI software.

Instruments with a measuring range from 500 to 3000 mm are available, all of them built in one single piece. All measuring ranges being direct, it means that the whole measuring range is available without adjustment or intermediate re-calibration.

IDEAL FOR THE USE IN LABORATORY AND IN THE WORKSHOP

NEW ERGONOMIC CONCEPT

MEASURING CARRIAGE WITH FINE ADJUSTMENT

LARGE RANGE OF ACCESSORIES

ADJUSTABLE MEASURING FORCE

3 DISPLAYS AVAILABLE

MODULAR SYSTEM DESIGN

DIRECT MEASUREMENT OVER THE WHOLE RANGE

DESCRIPTION



HORIZON PREMIUM

DISPLAY / SOFTWARE

HORIZON PREMIUM (HPA)

Heidenhain ND287 or ND1100 display units



Heidenhain ND1100



Heidenhain ND287



LINEAR MEASURING SYSTEM, MIN./MAX. VALUE HOLD

DIGITAL DISPLAY

ZERO SETTING OF THE DISPLAY AND PRESET INPUT

PARAMETER SETTINGS AND CLASSIFICATION

CONFIGURATION OF THE DISPLAY USING EXTERNAL CONTACT

RS232 DATA OUTPUT

HORIZON PREMIUM (HPD)

TRIMOS WinDHI

TRIMOS-WinDHI Software allows the performance of all required measuring functions and the connection to the temperature compensation system TempComp as well as to a gauge inspection and management system.



PC WITH TOUCH SCREEN

DDE-SERVER (FOR EXCEL, WORD, ETC.)

GRAPHIC HELP FOR MEASURING FUNCTIONS

DATA TRANSFER USING A FOOT PEDAL

DIGITAL DISPLAY OF THE SELECTED MEASURING FORCE IN NEWTON (N)

DIRECT DISPLAY OF ALL LENGTH MEASURING VALUES AND MIN./MAX. VALUE HOLD

MEASURING WITH 9 REFERENCES

INVERSION OF MEASURING DIRECTION SIGN (+/-)

COMPATIBLE WITH TEMPERATURE COMPENSATION SYSTEM TEMPCOMP (SEE § LABCONCEPT)

QMSOFT

Trimos recommends the QMSOFT software package for inspection and management of all measuring tools available.

INTEGRATED DRIVERS FOR TRIMOS INSTRUMENTS

REQUIRED NOMINAL SIZES AND TOLERANCES AVAILABLE ACCORDING ALL STANDARDS

CUSTOMIZED INSPECTION CERTIFICATES



TECHNICAL SPECIFICATIONS

Horizon Premium		500	1000	1500	2000	3000
Measuring range	mm (in)	550 (21)	1050 (41)	1550 (61)	2050 (80)	3050 (120)
Max. permissible errors ¹⁾	μm	0.7 + L (mm)/1000				
Repeatability (2s) ¹⁾	μm	0.2				
Resolutions	mm (in)	0.01 / 0.001 / 0.0001 (.001 / .0001 / .00001)				
Max. displacement speed	mm/s	1.5				
Measuring force	N	0 ÷ 12				
Operational temperature	°C	+10 ÷ +40				
Temperature of storage	°C	-10 ÷ +40				
Relative humidity	%	20 ÷ 80				
Weight	kg	94	123	152	181	239

¹⁾ Values valid at temperature of 20 ± 0.2 °C and relative humidity of 50 ± 5%.

SCHEMA

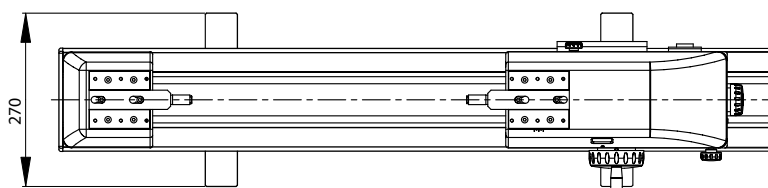
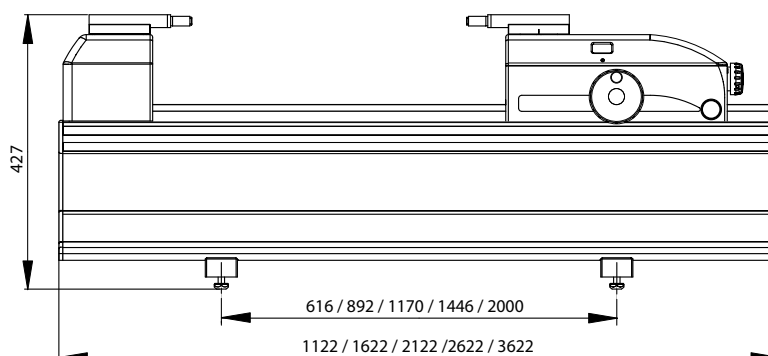

HORIZON PREMIUM

STANDARD INSTRUMENT

The Horizon Premium (HPA) instruments are supplied as follows:

Instrument according to specifications
Pair of anvils with tungsten carbide surface (HPA-1)
Lapping plate (TA-TO-302)
Protection cover (TEL.HO500 / 1000 / 1500 / 2000)
Allen key set (TA-TO-004)
User's manual (750 50 0015 03)
Test certificate

The Horizon Premium (HPD) instruments are supplied as follows:

Instrument according to specifications
Pair of anvils with tungsten carbide surface (HPA-1)
PC with interface, touch screen ¹⁾ , adjustable support ¹⁾ , touch screen pen ¹⁾
Foot pedal for data transfer (TELMA31)
Opto-RS connection cable for measuring force (TVM.O-PC/AT.9P)
Lapping plate (TA-TO-302)
Protection cover (TEL.HO500 / 1000 / 1500 / 2000)
Allen key set (TA-TO-004)
User's manual (750 50 0015 03)
Test certificate

¹⁾ Not included in version HPD-B. Touch screen replaced by a regular TFT screen.

CODE NUMBERS

Horizon Premium (HPA)		
HPA500	700 202 10 01	Measuring range 500 mm
HPA1000	700 202 20 01	Measuring range 1000 mm
HPA1500	700 202 30 01	Measuring range 1500 mm
HPA2000	700 202 40 01	Measuring range 2000 mm
HPA3000	700 202 50 01	Measuring range 3000 mm

Horizon Premium (HPD)				
HPD500	700 212 10 01	HPD500B	700 212 10 02 ¹⁾	Measuring range 500 mm
HPD1000	700 212 20 01	HPD1000B	700 212 20 02 ¹⁾	Measuring range 1000 mm
HPD1500	700 212 30 01	HPD1500B	700 212 30 02 ¹⁾	Measuring range 1500 mm
HPD2000	700 212 40 01	HPD2000B	700 212 40 02 ¹⁾	Measuring range 2000 mm
HPD3000	700 212 60 01	HPD3000B	700 212 60 02 ¹⁾	Measuring range 3000 mm

¹⁾ HPD-B: With TFT screen, no adjustable support.

APPLICATIONS

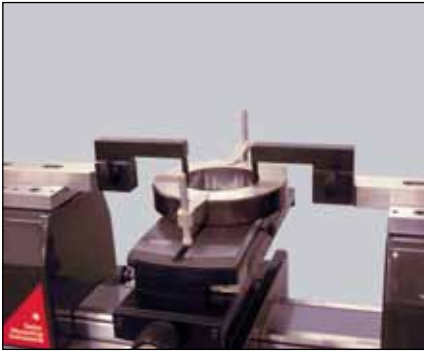

Checking of ring gauges
(TA-SU-313/TEL16.1/HPA-1)

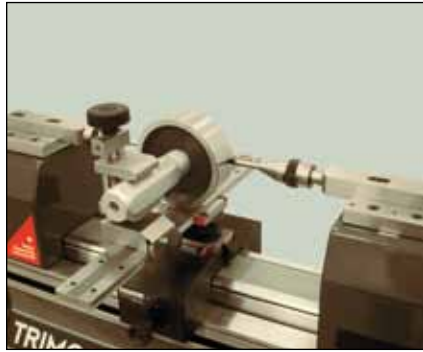

Checking of plug gauges
(HPA-1/TULM6/L05/LABC-15)



Checking of calipers (TEL5.10)

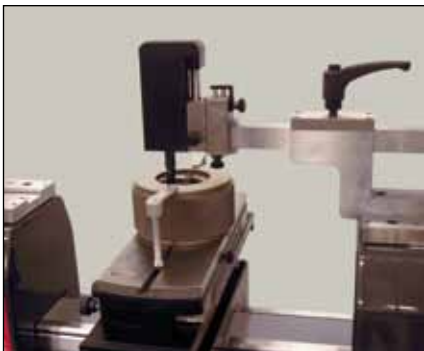

HPD: Checking of thread ring gauges
(TA-SU-313/LABC-70/TA-SU-354)



Checking of thread plug gauges (HPA-1/TEL6/3P/0.17-3.2/S6.5/LABC-15)



Checking of external micrometers
(HPA-1/TULM14)



Checking of snap gauges
(TA-SU-313/TEL14N)



Checking of dial indicators (TEL5CN)

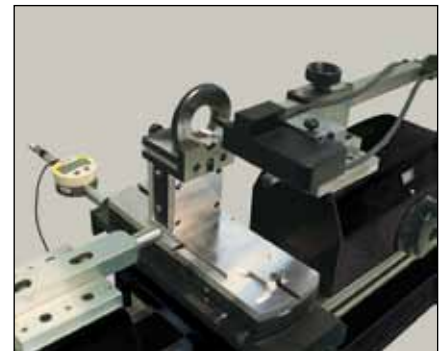

HPD: Checking of taper thread ring gauges (LABC80)

HORIZON PREMIUM

APPLICATIONS

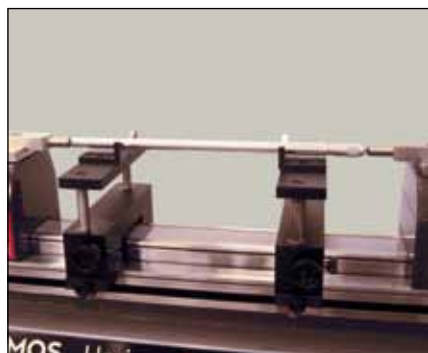

Setting of 2-point internal micrometers (HPA-1/TELMA7/TELMN7.2)

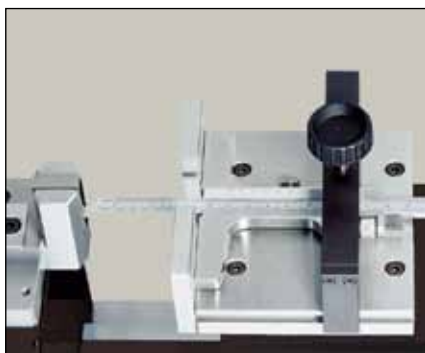

Checking of depth gauges (TEL5/TULM19)



HPA: Checking of thread ring gauges (TEL18)



HPA: Measurement of cylindrical parts (TA-MS-303)

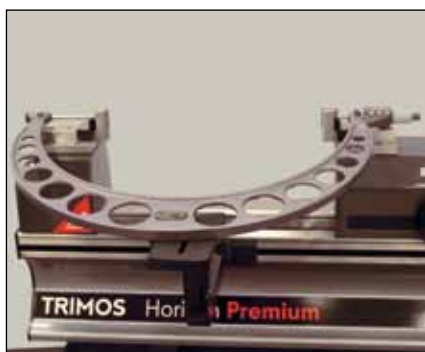

Large micrometer control (TEL5/TEL11/LABC20)



Setting of 2-point bore gauges (TEL5/TA-SU-301)



Setting of a large gauge (TEL5)

THV



THV

INTRODUCTION

The horizontal THV instrument has been designed for calibration and certification of gauging equipment of small dimension.

It allows easy and precise checking of plug gauges, ring gauges, thread plug gauges, test and dial indicators as well as measuring of high precision production parts.

The incorporated opto-electronic measuring system guarantees high accuracy. A separate display unit or a PC with Trimos WinDHI software can be used to display the measurement results.

The THV instruments can also be delivered without measuring system. An electronic probe or a dial indicator shall then be used as measuring system.

Due to its small size, The THV can be moved easily. It is therefore frequently used as mobile calibration station.

IDEAL FOR THE USE IN A CLEAN ROOM AND IN THE WORKSHOP AREA

THE INSTRUMENT MEETS THE REQUIREMENTS OF ALL EN ISO 9000

VERY SIMPLE MANIPULATION

LARGE RANGE OF ACCESSORIES

CHECKING OF INTERNAL AND EXTERNAL DIMENSIONS USING A SINGLE MEASURING ELEMENT

ACCORDING TO THE APPLICATION, THE INSTRUMENT CAN BE USED IN HORIZONTAL POSITION OR IT CAN BE INCLINED UPTO 90° USING THE ADDITIONAL STAND

DESCRIPTION

DISPLAY UNITS:



Heidenhain ND1100



PC with TRIMOS-WinDHI software

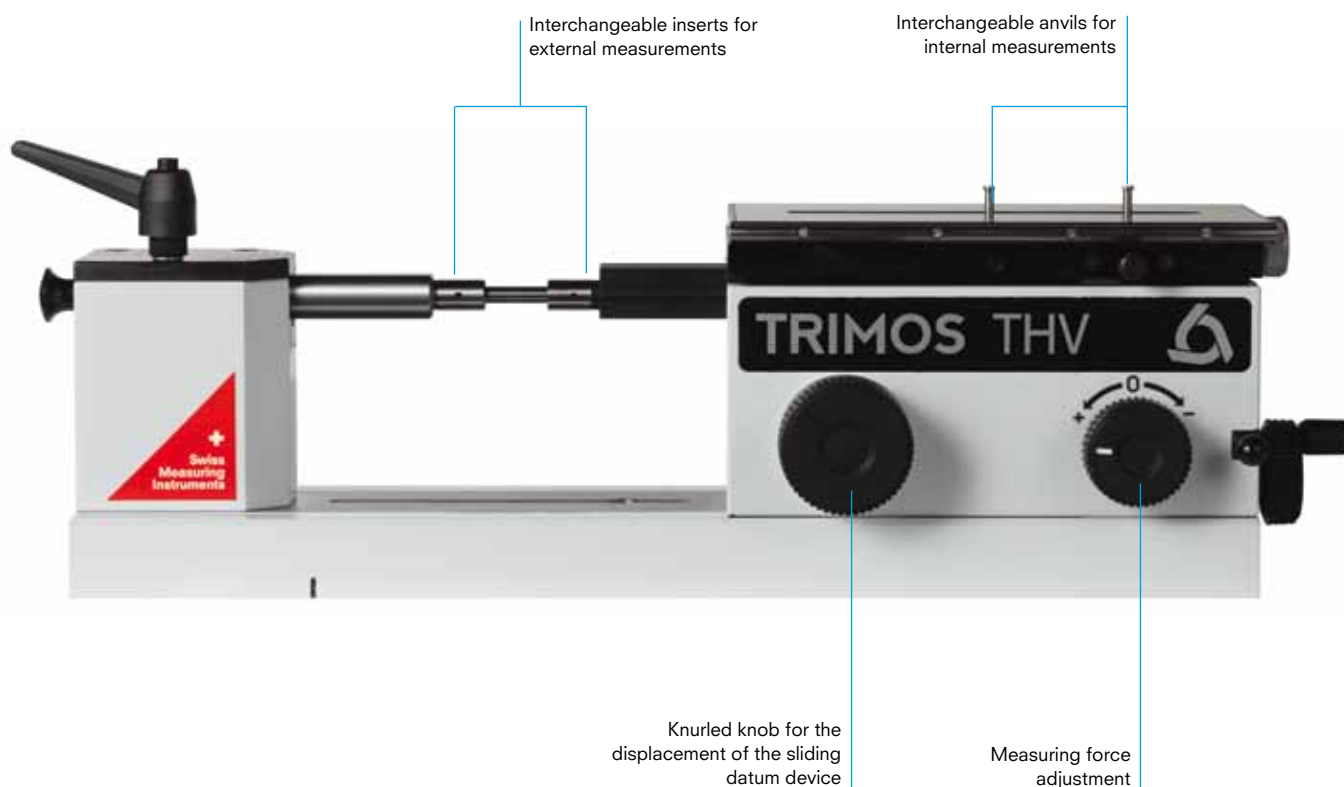

THV

DISPLAY / SOFTWARE

DISPLAY UNIT HEIDENHAIN ND1100

LINEAR MEASURING SYSTEM, MIN./MAX. VALUE HOLD

INVERSION OF MEASURING DIRECTION SIGN (+/-)

ZERO SETTING OF THE DISPLAY AND PRESET INPUT

PARAMETER SETTINGS AND CLASSIFICATION

CONFIGURATION OF THE DISPLAY USING EXTERNAL CONTACT

RS232 DATA OUTPUT



PC WITH TRIMOS WINDHI

TRIMOS-WinDHI Software allows the performance of all required measuring functions and the connection to a gauge inspection and management system.

INVERSION OF MEASURING DIRECTION SIGN (+/-)

DDE-SERVER (FOR EXCEL, WORD, ETC.)

GRAPHIC HELP FOR MEASURING FUNCTIONS

DATA TRANSFER USING A FOOT PEDAL

DIRECT DISPLAY OF ALL LENGTH MEASURING VALUES AND MIN./MAX. VALUE HOLD

MEASURING WITH 9 REFERENCES

COMPATIBLE WITH MEASURING EQUIPMENT MANAGEMENT SYSTEMS



TECHNICAL SPECIFICATIONS

THV		
Absolute measuring range	mm (in)	50 (2)
Application range (external measurements)	mm (in)	100 (4)
Application range (internal measurements)	mm (in)	100 (4)
Max. permissible errors ¹⁾	µm	0.2+ L (mm)/250
Repeatability (2s) ¹⁾	µm	0.1
Resolutions (depending on display unit)	mm (in)	0.1 ÷ 0.00001 (.0001 ÷ .000001)
Measuring force (adjustable)	N	0 ÷ 4
Operational temperature	°C	+10 ÷ +40
Temperature of storage	°C	-10 ÷ +40
Weight	kg	22

¹⁾ Instruments with integrated measuring system. Values valid at temperature of 20±0.2 °C and relative humidity of 50±5%.

SCHEMA

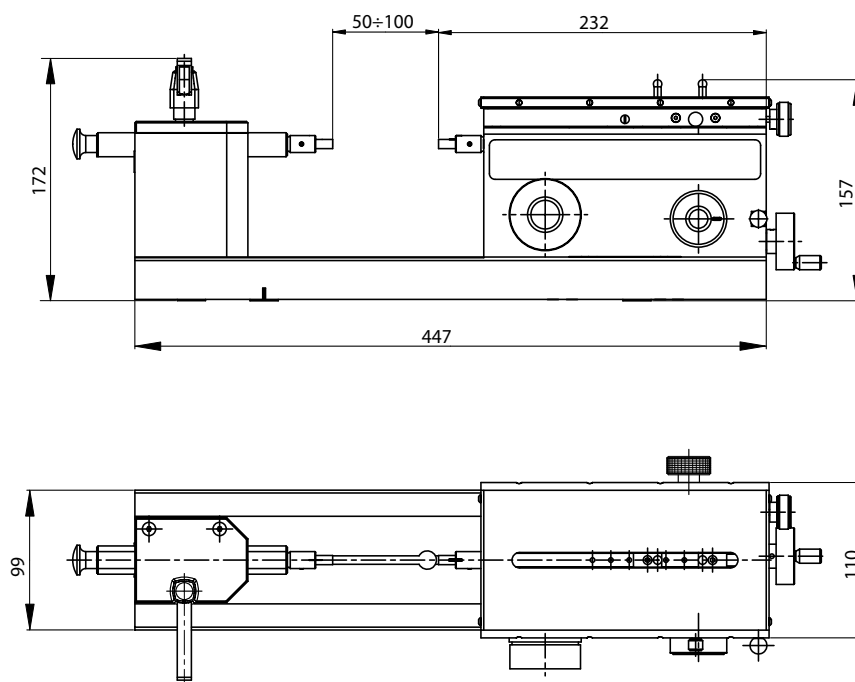

STANDARD INSTRUMENT

The THV instruments are supplied as follows:

Instrument according to specifications (without display)

Measuring inserts for external measurements (TELS50)

Measuring anvils for internal measurements (THV-10)

Protection cover (THV.HO.0-50)

User's manual (750 50 0006 03)

Test certificate

CODE NUMBERS

THV	Rigid table	Floating table
Instruments with measuring system	THVR.0-50 700 206 00 22	THVR.0-50S 700 206 00 24
Instruments without measuring system	THV.0-50 700 206 00 21	THV.0-50S 700 206 00 01

THV

APPLICATIONS



Calibration of plain and threaded plug gauges using the floating table (THV-115)



Calibration of plain rings gauges (THV-260)

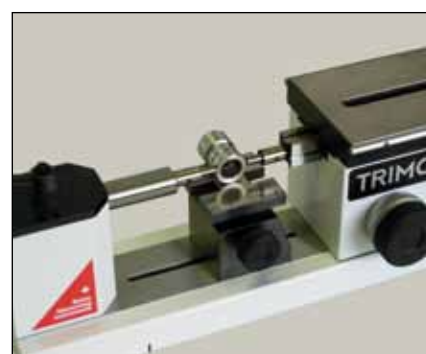

Measuring of precision parts (THV-100/THV-101)



Checking of test indicators (THV-100/THV-150)



Adjustable support for a constant measuring force (THV-200)



Floating table for more accurate internal measurements

LABCONCEPT + Premium



LABCONCEPT + Premium

INTRODUCTION

The Labconcept and Labconcept Premium are high precision calibration systems that meet the most sophisticated requirements.

The up-to-date, well designed modular concept enables extremely secure functioning, facilitates the manipulation and therefore increases the productivity in the measuring laboratory. Simplicity and high accuracy have been associated.

This new concept, integrating a computer and a touch screen as well as the appropriate Trimos-WinDHI software with all necessary measuring functions guarantees the best results. A temperature compensation system as well as a gauge management system can be installed to enhance the system performance.

Instruments with a measuring range from 300 to 2000 mm are available, all made in one single piece. All measuring ranges being direct, it means that the whole measuring range is available without adjustment or intermediate re-calibration.

MEETS THE REQUIREMENTS OF ALL EN ISO 9000

PC WITH EXCLUSIVE SOFTWARE WINDHI

HIGH PRECISION MEASURING SYSTEM

DIMENSIONALLY STABLE INSTRUMENT BASE

ADJUSTABLE MEASURING FORCE (FROM 0 TO 12 N)

LARGE RANGE OF ACCESSORIES

DIRECT MEASUREMENT OVER THE WHOLE
MEASURING RANGE

DESCRIPTION

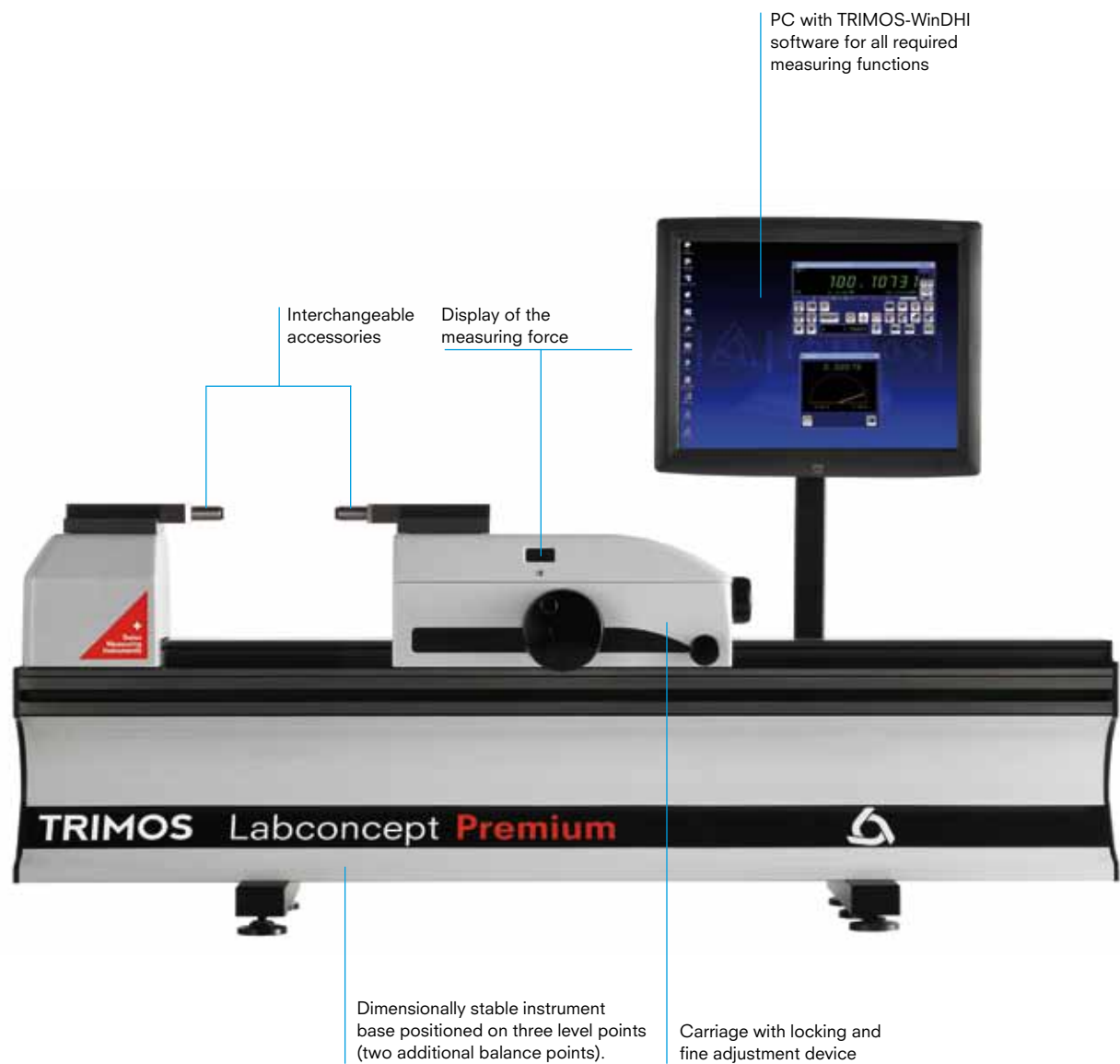

LABCONCEPT + Premium

DISPLAY / SOFTWARE

TRIMOS WINDHI

TRIMOS® WinDHI Software allows the performance of all required measuring functions. It can be connected to the temperature compensation software WinComp and to any gauge inspection and management program.

DDE-SERVER (FOR EXCEL, WORD, ETC.)

GRAPHIC HELP FOR MEASURING FUNCTIONS

DATA TRANSFER USING A FOOT PEDAL

DIGITAL DISPLAY OF THE SELECTED MEASURING FORCE IN NEWTON (N)

DIRECT DISPLAY OF ALL LENGTH MEASURING VALUES AND MINI/MAX VALUE HOLD

INPUT OF 9 PRESET VALUES

INVERSION OF MEASURING DIRECTION SIGN (+/-)

COMPATIBLE WITH TEMPERATURE COMPENSATION SYSTEM TEMPCOMP



QMSOFT

Trimos recommends the QMSOFT software package for inspection and management of all measuring tools available.

INTEGRATED DRIVERS FOR TRIMOS INSTRUMENTS

REQUIRED NOMINAL SIZES AND TOLERANCES AVAILABLE ACCORDING TO ALL STANDARDS

CUSTOMIZED INSPECTION CERTIFICATES



DISPLAY / SOFTWARE

TEMPERATURE COMPENSATION SYSTEM TRIMOS TEMPCOMP

The Temperature Compensation System TempComp gives a solution to air conditioning problems in measuring laboratories.

COMPATIBLE WITH HPD, LABCONCEPT, LABCONCEPT PREMIUM AND LABCONCEPT NANO INSTRUMENTS

TRIMOS WINCOMP EXCLUSIVE SOFTWARE

ACQUISITION AND MANAGEMENT OF TEMPERATURE DATA

PERMANENT CONNECTION WITH WIN DHI

REAL-TIME COMPENSATION OF THE MEASUREMENT

TEMPERATURE EVOLUTION HISTORY OVER SEVERAL YEARS FOR A PERFECT TRACEABILITY

GRAPHICAL DISPLAY OF TEMPERATURE EVOLUTION

MATERIALS LIBRARY

INDICATION OF THE MEASUREMENT RELIABILITY LEVEL

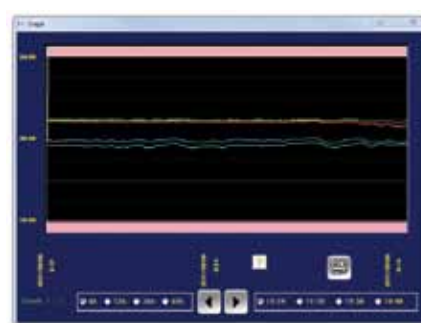

TEMPCOMP BASIC

BASIC TEMPERATURE COMPENSATION SYSTEM

2 TEMPERATURE SENSORS:

A PART TO BE MEASURED
B MEASURING CARRIAGE

TEMPCOMP PREMIUM

PART TO BE MEASURED

3 TEMPERATURE SENSORS:

A PART TO BE MEASURED
B MEASURING CARRIAGE
C INSTRUMENT BASE

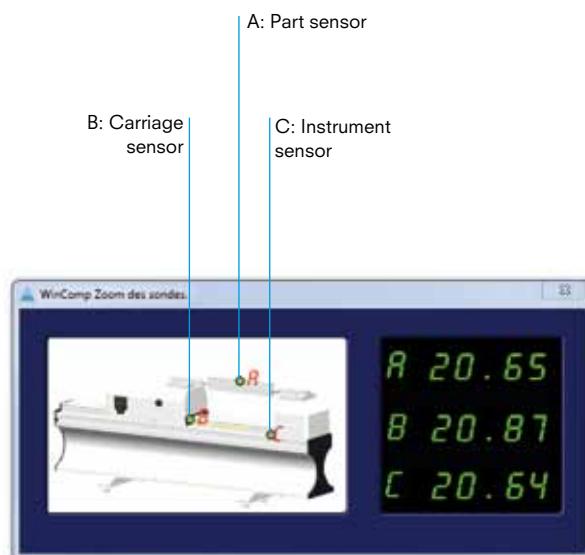

TempComp Basic & Premium		
Application range (temperature)	°C	+16 ÷ +24
Max. resolution (temperature)	°C	0.01
Max. permissible errors (temperature)	°C	0.05

LABCONCEPT + Premium

DISPLAY / SOFTWARE

TEMPCOMP ADVANCED

The environment control system TempComp Advanced represents an evolution of the temperature compensation system TempComp.

Tempcomp is an exclusive temperature compensation system with environmental parameter verification of the laboratory. The temperature acquisition is managed by WinComp Advanced software. It offers, on top of WinComp functionalities, the possibility to check the laboratory in real time via Internet, Intranet, mobile phone, etc..



INTEGRATED TEMPERATURE COMPENSATION SYSTEM FOR LABORATORY

3 TEMPERATURE SENSORS ON THE INSTRUMENT:

- PART TO BE MEASURED
- MEASURING CARRIAGE
- INSTRUMENT BASE

4 TEMPERATURE SENSORS IN THE LABORATORY

1 RELATIVE HUMIDITY SENSOR

1 ATMOSPHERIC PRESSURE SENSOR

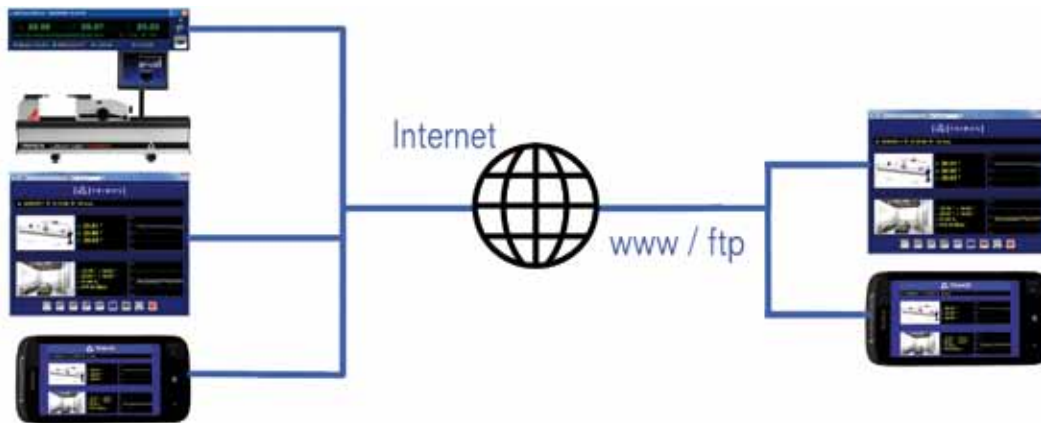

TempComp Advanced		
Application range (temperature)	°C	+16 ÷ +24
Max. resolution (temperature)	°C	0.01
Max. permissible errors (instrument temperature)	°C	0.05
Max. permissible errors (environmental temperature)	°C	0.16
Max. permissible errors (humidity)	%	± 2
Max. permissible errors (pressure)	mbar	± 0.5 %

TECHNICAL SPECIFICATIONS

Labconcept		500	1000	1500	2000
Measuring range	mm (in)	550 (21)	1050 (41)	1550 (61)	2050 (80)
Max. permissible errors ¹⁾	µm	0.3 + L (mm) / 1500			
Repeatability (2s) ¹⁾	µm	0.1			
Resolutions	mm (in)	0.01 ÷ 0.00001 (.0001 ÷ .000001)			
Max. displacement speed	mm/s	1500			
Measuring force	N	0 ÷ 12			
Operational temperature	°C	+10 ÷ +40			
Temperature of storage	°C	-10 ÷ +40			
Relative humidity	%	20 ÷ 80			
Weight	kg	94	123	152	181

¹⁾ Values valid at temperature of 20 ± 0.2 °C and relative humidity of 50 ± 5%.

Labconcept Premium		300	500	1000
Measuring range	mm (in)	370 (14)	550 (21)	1050 (41)
Max. permissible errors ¹⁾	µm	0.1 + L (mm) / 2000	0.15 + L (mm) / 2000	
Repeatability (2s) ¹⁾	µm	0.05		
Resolutions	mm (in)	0.01 ÷ 0.00001 (.0001 ÷ .000001)		
Max. displacement speed	mm/s	400		
Measuring force	N	0 ÷ 12		
Operational temperature	°C	+10 ÷ +40		
Temperature of storage	°C	-10 ÷ +40		
Relative humidity	%	20 ÷ 80		
Weight	kg	78	95	125

¹⁾ Values valid at temperature of 20 ± 0.2 °C and relative humidity of 50 ± 5%.

SCHEMA

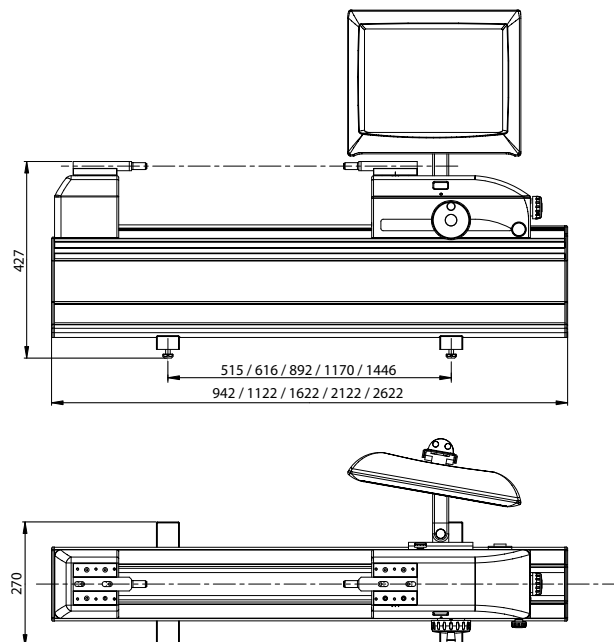

LABCONCEPT + Premium

STANDARD INSTRUMENT

The Labconcept and Labconcept Premium instruments are supplied as follows:
Instrument according to specifications
Pair of anvils with tungsten carbide surface (HPA-1)
PC with interface, touch screen ¹⁾ with adjustable support ¹⁾ and touch screen pen ¹⁾
Foot pedal for data transfer (TELMA31)
Opto-RS connection cable for measuring force (TVM.O-PC / AT.9P)
Lapping plate (TA-TO-302)
Protection cover (TEL.HO500 / 1000 / 1500 / 2000)
Allen key set (TA-TO-004)
User's manual (750 50 0015 03)
Test certificate

¹⁾ Not included in versions LABC-B. Touch screen replaced by a regular TFT screen.

CODE NUMBER

With touch screen	With TFTscreen	Labconcept
LABC500 700 203 10 01	LABC500B 700 203 10 02	Measuring range 500 mm
LABC1000 700 203 20 01	LABC1000B 700 203 20 02	Measuring range 1000 mm
LABC1500 700 203 30 01	LABC1500B 700 203 30 02	Measuring range 1500 mm
LABC2000 700 203 40 01	LABC2000B 700 203 40 02	Measuring range 2000 mm

With touch screen	With TFTscreen	Labconcept Premium
	LABCP300B 700 203 10 13	Measuring range 300 mm
LABCP500 700 203 10 11	LABCP500B 700 203 10 12	Measuring range 500 mm
LABCP1000 700 203 20 11	LABCP1000B 700 203 20 12	Measuring range 1000 mm

APPLICATIONS



Calibration of ring gauges
(TA-SU-313/TEL16.1/HPA-1)

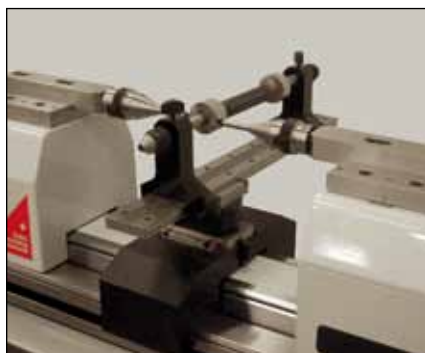

Calibration of plug gauges
(HPA-1/TULM6/L05/LABC-15)



Calibration of small ring gauges
(TA-SU-313/LABC-70/TA-SU-354)



Calibration of thread ring gauges
(TA-SU-313/LABC-70/TA-SU-354)



Calibration of thread plug gauges
(HPA-1/TEL6/3P/0.17-3.2/S6.5/LABC-15)



Calibration of external micrometers
(HPA-1/TULM14)

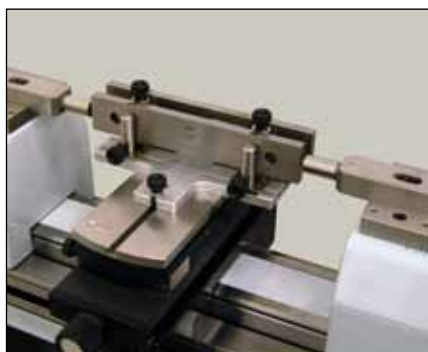

Comparative checking of gauge blocks < 250 mm
(TA-SU-313/TA-SU-305)



Comparative checking of gauge blocks > 250 mm
(TA-SU-313/TELMA7/P/TA-SU-305/TA-SU-306)



Setting of 2-point internal micrometers
(HPA-1/TELMA7/TELMN7.2)

LABCONCEPT + Premium

APPLICATIONS

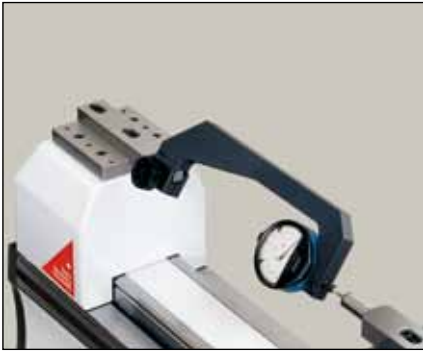

Checking of dial indicators (TULM5C)

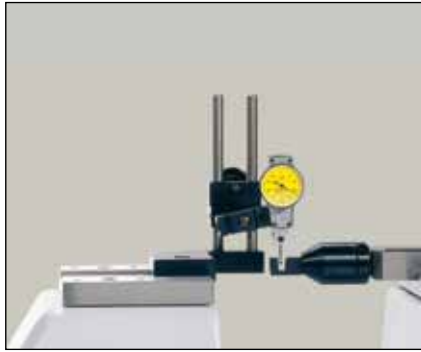

Checking of test indicators (TULM15)



Checking of snap gauges (TA-SU-313/TEL14N)



Temperature compensation system
TempComp

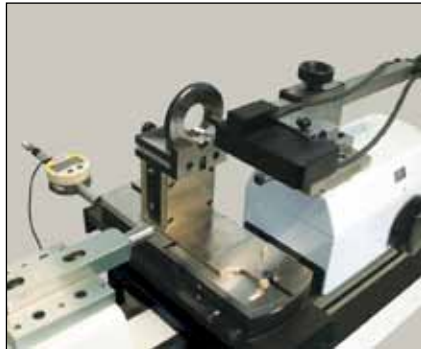

Checking of taper thread ring gauges
(HPA-1/LABC80)

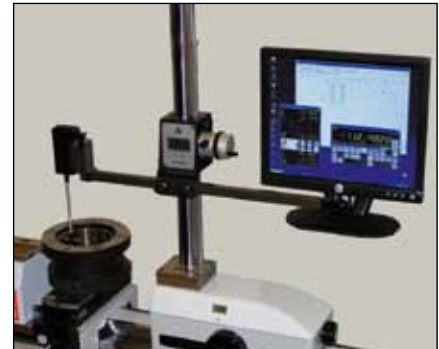

Special design for measurement of
large taper threaded gauges



Direct measurement over the whole measuring range.

LABCONCEPT Nano



LABCONCEPT Nano

INTRODUCTION

No compromise on accuracy

The Labconcept Nano is a new reference in the field of dimensional metrology. It integrates 40 years of knowledge and continuous improvement. It is a remarkable instrument for all measuring tasks that require extremely high accuracy.

The uncompromising design of the Labconcept Nano offers an ideal and performing platform for checking and calibration of all kinds of gauges and measuring instruments. Checking of internal and external dimensions will be done as a fully automatic procedure by the three motorized axes XYZ and the legendary simplicity of use of Trimos WinDHI software.

The Labconcept Nano is completely designed and manufactured in Switzerland according to the highest quality standards. Robustness, reliability and longevity are our traditional values.

A New Technological Dimension

The Labconcept Nano combines tradition, experience and a strong technological lead. It integrates the latest measuring and motorisation technologies and can be considered as the first "full digital" calibration instrument. A regular PC controls all electronic components. This low-power solution avoids heating and keeps the energy, maintenance and repair costs at a reasonable level. The linear bearings used in all guideways have proven their superiority over all other technologies in terms of precision, wear, rigidity, temperature stability, reliability, dust protection and maintenance. They ensure exceptional repeatability and precision through time.

UNEQUALLED HIGH LEVEL OF ACCURACY

EXCEPTIONAL REPEATABILITY

MOTORIZED MEASURING CARRIAGE, X AXIS,
SELECTION OF SPEED BY SOFTWARE

MOTORIZED UNIVERSAL MEASURING TABLE, CNC Y
AND Z AXIS WITH INTEGRATED MEASURING SYSTEM

MEASURING FORCE (0-12N) AND LOCKING OF
MEASURING ANVIL PERFORMED BY SOFTWARE

INTEGRATED TEMPERATURE COMPENSATION SYSTEM

ABSOLUTE MEASURING RANGE ON
ALL MODELS: 350 MM

APPLICATION RANGES OF 350, 600 AND 1100 MM

MEASURING OF PARTS UP TO 60 KG IN WEIGHT

2 SCREENS IN THE STANDARD PACKAGE

CNC CONTROLLED MEASUREMENTS EVEN ON
DIAMETERS AND THREADS

DESCRIPTION

motorized measuring table (YZ)

CNC controlled measuring carriage (X)

PC with 2 screens including WinDHI software for measurements and WinComp for temperature compensation



Ergonomic and compact Workbench

LABCONCEPT Nano

DISPLAY / SOFTWARE

TRIMOS WINDHI NANO

Trimos Win DHI Nano is the exclusive measurement software of Trimos. It is part of the basic equipment of the Labconcept Nano and allows the performance of all measuring functions. It helps the user to perform all measurement tasks through a user-friendly interface.

The motorization of the measuring carriage (X) and both vertical (Z) and horizontal (Y) axis of the universal measuring table allow an exceptional performance in terms of measuring speed, ease of use and accuracy.

Positioning can be done easily using the mouse and the keyboard or via the touch screen (optional) or a joystick (optional). Once positioned, measurements are entirely CNC controlled, including searching the reversal point. Plug and ring gauges, threaded ring and plug gauges etc. can be measured automatically in a few seconds. No risk of damage to the sensitive probes while moving or measuring, even with tiny parts and inserts.

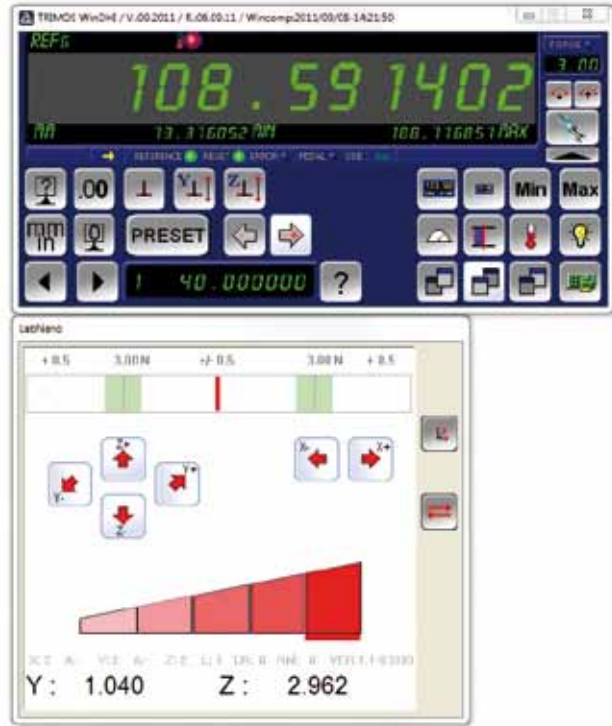

- 100 % AUTOMATIC MEASUREMENTS

- MEASUREMENTS PERFORMED IN A FEW SECONDS

- USER FRIENDLY INTERFACE

- GRAPHIC HELP FOR MEASURING FUNCTIONS

- ELECTRONICALLY ADJUSTABLE MEASURING FORCE

- DATA TRANSFER USING A FOOT SWITCH

- DDE SERVER (FOR EXCEL, WORD, ETC.)

TRIMOS WINCOMP

The Labconcept Nano is equipped as standard with a temperature compensation system Trimos WinComp allowing the acquisition and management of temperature data.

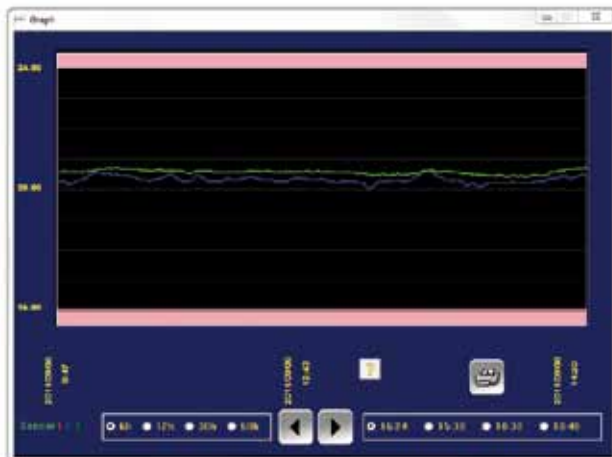

- TRIMOS WINCOMP EXCLUSIVE SOFTWARE

- ACQUISITION AND MANAGEMENT OF TEMPERATURE DATA

- PERMANENT CONNECTION WITH WIN DHI

- REAL - TIME COMPENSATION OF THE MEASUREMENT

- TEMPERATURE EVOLUTION HISTORY OVER SEVERAL YEARS FOR A PERFECT TRACEABILITY

- GRAPHICAL DISPLAY OF TEMPERATURE EVOLUTION

- MATERIALS LIBRARY

- INDICATION OF THE MEASUREMENT RELIABILITY LEVEL

DISPLAY / SOFTWARE

QMSOFT

Trimos recommends the QMSOFT software package for inspection and management of all measuring tools available.

INTEGRATED DRIVERS FOR TRIMOS INSTRUMENTS

REQUIRED NOMINAL SIZES AND TOLERANCES
AVAILABLE ACCORDING TO ALL STANDARDS

CUSTOMIZED INSPECTION CERTIFICATES



TECHNICAL SPECIFICATIONS

Labconcept Nano		350	600	1100
Application range	mm (in)	350 (13.2)	600 (23.6)	1100 (43.3)
Absolute measuring range	mm (in)	350 (13.2)		
Max. permissible errors ¹⁾	µm	0.07+L(mm) / 2000		
Repeatability (2s) ¹⁾	µm	0.03		
Max. resolution	mm (in)	0.000001 (0.0000001)		
Measuring force (adjustable by software)	N	0 ÷ 12		
Operational temperature	°C	+15 ÷ +35		
Temperature of storage	°C	-10 ÷ +40		
Relative humidity	%	20 ÷ 80		
Weight	kg	350	420	500

¹⁾ Values valid at temperature of 20 ± 0.2 °C and relative humidity of 50 ± 5%.

Measuring table with motorized Y and Z axes		
Z axis, displacement range ²⁾	mm (in)	100 (4)
Y axis, displacement range ²⁾	mm (in)	50 (2)
X axis, floating movement	µm	± 10
Angle of inclination (Y)	°	± 1.5
Angle of rotation (Z)	°	± 4
Max. weight of parts	kg	60

²⁾ Both axes Y and Z have an integrated measuring system.

LABCONCEPT Nano

SCHEMA

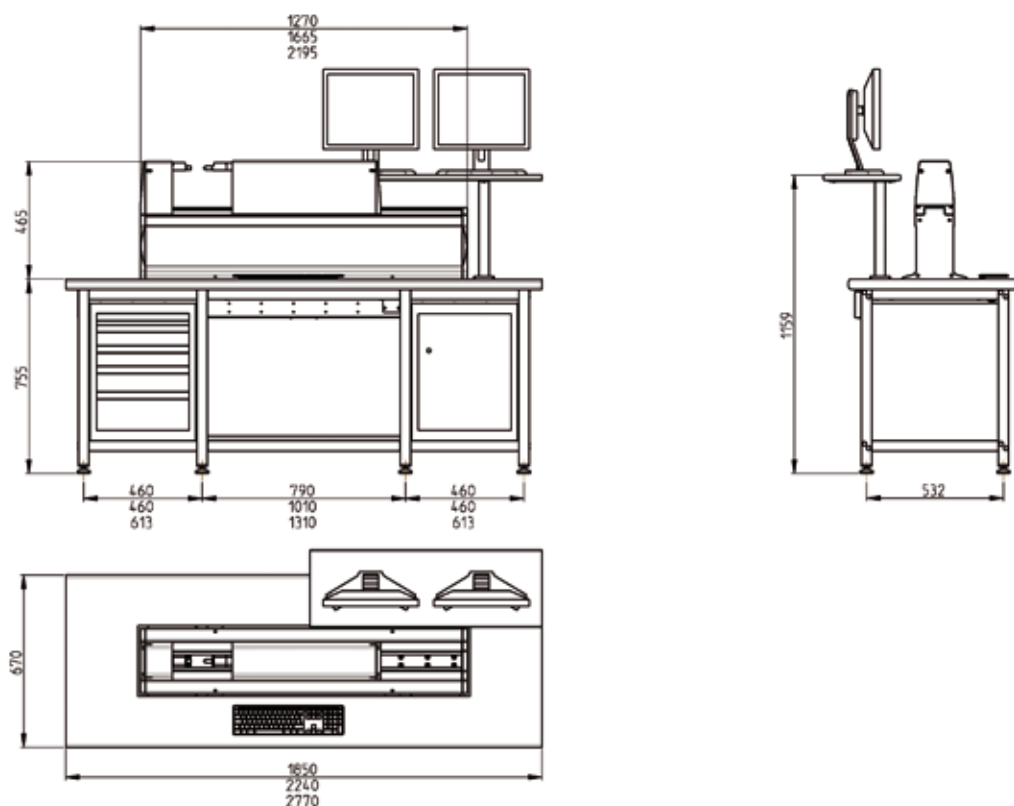

STANDARD INSTRUMENT

The Labconcept Nano are supplied as follows :

- Instrument according to specifications with tungsten carbide surface anvils
- Universal measuring table with motorized Y and Z axes (Nano-14)
- PC with interface, 2 LCD TFT screens and 1 printer
- Foot pedal for data transfer (TELMA31)
- Specially designed workbench with 1 drawer cabinet and 1 door cabinet
- Temperature compensation system (TEMPCOMP-B)
- Lapping plate (TA-TO-302)
- Protection cover (TEL.HO500 / 1000 / 1500)
- Allen key set (TA-TO-004)
- User's manual (750 50 0039 03)
- Test certificate

CODE NUMBERS

Labconcept Nano	Standard workbench	Anti-vibration workbench	
LABC-NANO 350 700 213 00 01	TA-TO-306 714 12 006	TA-TO-310 714 12 010	Measuring range 350 mm
LABC-NANO 600 700 213 10 01	TA-TO-307 714 12 007	TA-TO-311 714 12 011	Measuring range 600 mm
LABC-NANO 1100 700 213 20 01	TA-TO-308 714 12 008	TA-TO-312 714 12 012	Measuring range 1100 mm

APPLICATIONS

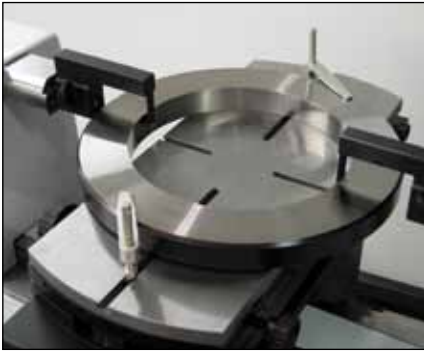

Calibration of plain ring gauges
(TEL16.1/TA-SU-354)

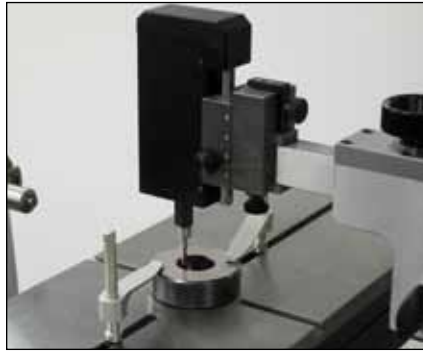

Calibration of small plain ring gauges
(TA-MS-370/TEL76/TA-SU-354)

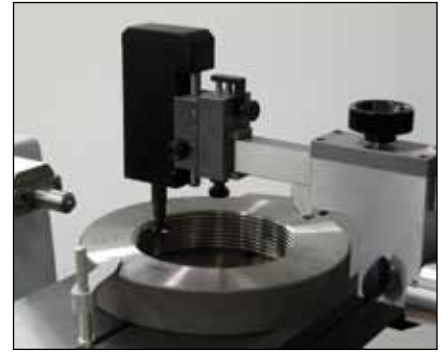

Calibration of thread ring gauges
(TA-MS-370/TEL75/TA-SU-354)



Calibration of plug gauges
(TULM6/L05/TA-SU-315)



Calibration of thread plug gauges
(3P/0.17-3.2/S6.5/TA-SU-315)



Comparative checking of gauge blocks
> 250 mm (TA-SU-307/TEL7/TELM7)



Calibration of gauge bars
(TELM7/TELMN7.2)

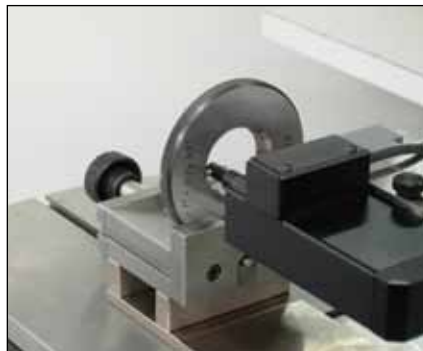

Checking of taper thread ring gauges
(TA-MS-381/TEL75)



Checking of taper thread plug gauges
(TA-MS-381/TEL75)

LABCONCEPT Nano

APPLICATIONS



Calibration of snap gauges
(TEL16.1/TEL14N)

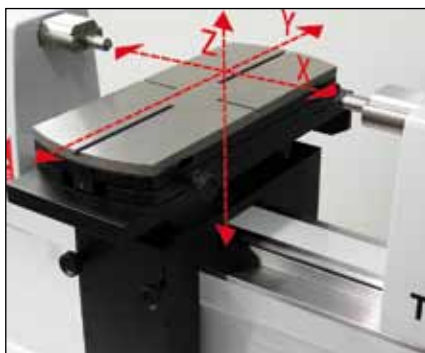

CNC-controlled measurement with
automatic reversal point search.



Anti-vibration table (optional)



Integrated temperature compensation
system TempComp

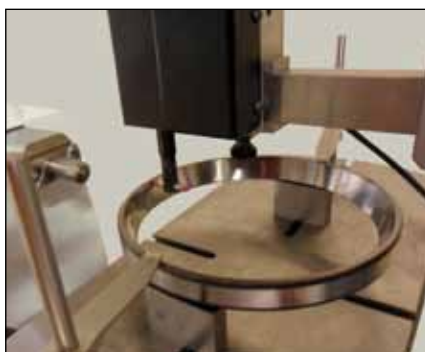

CNC controlled internal taper ring
measurement



CNC controlled external taper ring
measurement



CNC controlled internal measurement
of a bearing ring

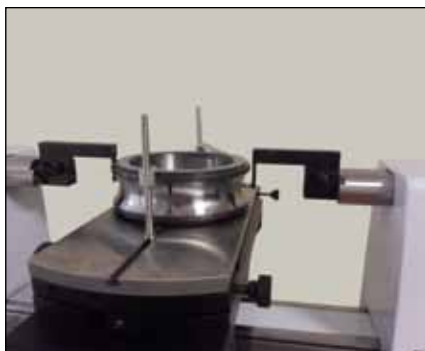

CNC controlled external
measurement of a bearing ring



Calibration of a specific gauge

ACCESSORIES

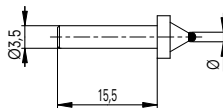
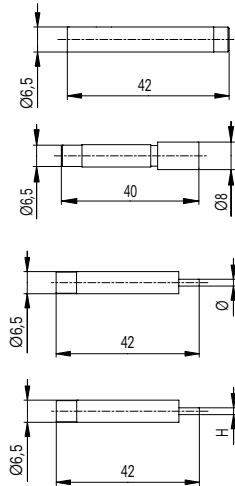

		TELS	ALESTA	H	HG	HPA	HPD	THV	LABC + P	LBCN
TELS50 609 05 044	Pair of measuring anvils Ø 6.5 mm	•						•		
TELS52 609 05 047	Pair of measuring anvils Ø 8 mm	•			•	•	•	•	•	•
TELS53 609 05 048	Pair of measuring anvils Ø 2 mm	•			•	•	•	•	•	•
TELS53/D1 SP609 05 048 01	Pair of measuring anvils Ø 1 mm	•			•	•	•	•	•	•
TELS50-L05 SP609 05 044 01	Pair of a knife-shaped anvils	•						•		
TA-MI-301 279 901008 001	Ball probe Ø 1.00 mm	•						•		
TA-MI-302 279 901008 002	Ball probe Ø 1.250 mm	•						•		
TA-MI-303 279 901008 003	Ball probe Ø 1.50 mm	•						•		
TA-MI-304 279 901008 004	Ball probe Ø 1.75 mm	•						•		
TA-MI-305 279 901008 005	Ball probe Ø 2.00 mm	•						•		
TA-MI-306 279 901008 006	Ball probe Ø 2.032 mm	•						•		
TA-MI-307 279 901008 007	Ball probe Ø 2.20 mm	•						•		
TA-MI-308 279 901008 008	Ball probe Ø 2.25 mm	•						•		
TA-MI-309 279 901008 009	Ball probe Ø 2.50 mm	•						•		
TA-MI-310 279 901008 010	Ball probe Ø 2.75 mm	•						•		
TA-MI-311 279 901008 011	Ball probe Ø 3.00 mm	•						•		
TA-MI-312 279 901008 012	Ball probe Ø 3.20 mm	•						•		
TA-MI-313 279 901008 013	Ball probe Ø 3.25 mm	•						•		
TA-MI-314 279 901008 014	Ball probe Ø 3.50 mm	•						•		



ACCESSORIES

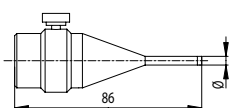
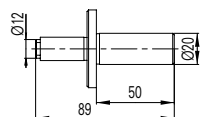
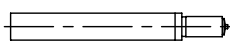
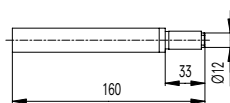
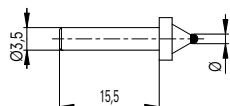

		TELS	ALESTA	H	HG	HPA	HPD	THV	LABC + P	LABCN
TA-MI-315 279 901008 015	Ball probe Ø 3.70 mm	•						•		
TA-MI-316 279 901008 016	Ball probe Ø 4.00 mm	•						•		
TA-MI-317 279 901008 017	Ball probe Ø 4.50 mm	•						•		
TA-MI-318 279 901008 018	Ball probe Ø 5.00 mm	•						•		
TA-MI-319 279 901008 019	Ball probe Ø 5.50 mm	•						•		
TA-MI-320 279 901008 020	Ball probe Ø 6.00 mm	•						•		
TA-MI-321 279 901008 021	Ball probe Ø 6.50 mm	•						•		
TA-MI-322 279 901008 022	Ball probe Ø 7.00 mm	•						•		
TA-MI-323 279 901008 023	Ball probe Ø 8.00 mm	•						•		
TA-MI-324 279 901008 024	Ball probe Ø 9.00 mm	•						•		
TA-MI-325 279 901008 025	Ball probe Ø 10.00 mm	•						•		
HPA-1 609 05 017	Pair of standard anvils			•		•	•		•	
TA-MI-350 609 05 105	Pair of anvils with radius 30 mm for gauge block					•	•		•	
TEL1 609 05 040	Anvil with tungsten carbide surface				•					
TEL6 609 05 041	Pair of anvils Ø 6.50 mm			•	•	•	•		•	•
TEL6/4 609 05 077	Pair of anvils Ø 4 mm			•	•	•	•		•	•
TEL6/6 609 05 078	Pair of anvils Ø 6 mm			•	•	•	•		•	•
TEL6/6.35 609 05 079	Pair of anvils Ø 6.35 mm			•	•	•	•		•	•

ACCESSORIES

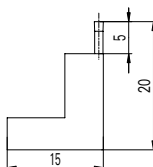
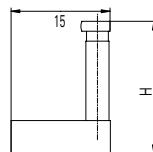
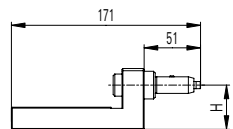
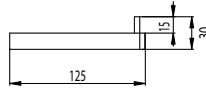
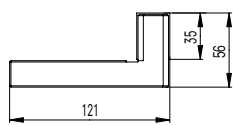
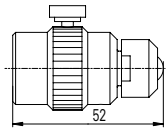
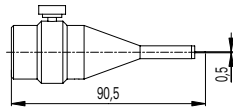
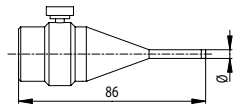

		TELS	ALESTA	H	HG	HPA	HPD	THV	LABC + P	LABCN
TEL6/6.8 609 05 080	Pair of anvils Ø 6.8 mm			•	•	•	•		•	•
TEL6/8 609 05 081	Pair of anvils Ø 8 mm			•	•	•	•		•	•
TEL6/10 609 05 079	Pair of anvils Ø 10 mm			•	•	•	•		•	•
TULM6/L05 609 05 016	Pair of a knife-shaped anvils			•	•	•	•		•	•
TEL7 609 05 013	Pair of anvils with ball Ø 10 mm			•	•	•	•		•	•
TEL5 609 05 101	Pair of parallel attachments 25 mm			•	•	•	•		•	
TEL5E 609 05 102	Pair of parallel attachments 1"			•	•	•	•		•	
TEL5.10 612 12 002	Pair of parallel attachments 5 mm, for ext. measurement from 20 mm			•		•	•		•	
TEL5.10E 612 12 007	Pair of parallel attachments .2", for ext. measurement from .8"			•		•	•		•	
TELMA5.0 609 05 005	Pair of holders with measuring inserts TELS50, H=40 mm			•		•	•		•	
TELMA5.0/H70 SP609 05 005 01	Pair of holders with measuring inserts TELS50, H=70 mm			•		•	•		•	
TELMA5.0/H88 SP609 05 005 02	Pair of holders with measuring inserts TELS50, H=88 mm			•		•	•		•	
TELMA5.0/H55 SP609 05 005 03	Pair of holders with measuring inserts TELS50, H=55 mm			•		•	•		•	
TELMA5.0/H65 SP609 05 005 04	Pair of holders with measuring inserts TELS50, H=65mm			•		•	•		•	
TELS10 609 05 042	Pair of inserts for int. meas. >Ø10, H=20 mm	•								
TELS10/H50 609 05 043	Pair of inserts for int. meas. >Ø10, H=50 mm	•								
TELS10/H35 SP609 05 043 01	Pair of inserts for int. meas. >Ø10, H=35 mm	•								
TELS10/1.5C SP609 05 070 01	Pair of inserts for int. meas. >Ø3 mm	•								



ACCESSORIES

		TELS	ALESTA	H	HG	HPA	HPD	THV	LABC + P	LABCN
	TELS11 609 05 058	●								
	TELS11.1 609 05 103	●								
	TELS12 609 05 060	●								
	TELS13 609 05 033	●								
	THV-10 609 05 034							●		
	THV-11 609 05 032							●		
	THV-12 609 05 035							●		
	THV-15 609 05 092							●		
	THV-20 609 05 037							●		
	THV-21 609 05 038							●		
	THV-22 609 05 039							●		
	THV-25 609 05 091							●		
	THV-26 609 05 094							●		
	TEL16.1 609 05 088					●	●		●	●

ACCESSORIES

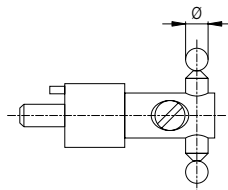
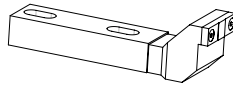
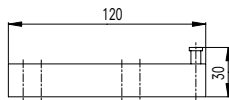
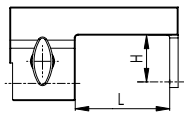

		TELS	ALESTA	H	HG	HPA	HPD	THV	LABC + P	LBCN
TEL16.2 609 05 089	Pair of L-shaped probes, H=40 mm, L=55 mm					•	•		•	•
TEL16.3 609 05 097	Pair of L-shaped probes, H=70/45 mm, L=65mm					•	•		•	•
TEL9 612 12 008	Pair of inserts for internal meas. >Ø20 mm, with air cushion			•	•					
TEL9.10 612 12 009	Pair of inserts for internal meas. >Ø10 mm, with air cushion			•	•					
TELMN9 612 11 002	Pair of inserts for internal meas. >Ø10 mm, without air cushion			•	•					
TELMA8 612 12 052	Pair of measuring devices for snap-gauges			•	•	•	•		•	
TEL75.01 298 000205 050	T-shaped measuring insert, ruby balls Ø0.335 mm					•	•		•	•
TEL75.1 298 000205 051	T-shaped measuring insert, ruby balls Ø0.455 mm					•	•		•	•
TEL75.2 298 000205 052	T-shaped measuring insert, ruby balls Ø0.530 mm					•	•		•	•
TEL75.3 298 000205 053	T-shaped measuring insert, ruby balls Ø0.620 mm					•	•		•	•
TEL75.4 298 000205 054	T-shaped measuring insert, ruby balls Ø0.725 mm					•	•		•	•
TEL75.5 298 000205 055	T-shaped measuring insert, ruby balls Ø0.895 mm					•	•		•	•
TEL75.6 298 000205 056	T-shaped measuring insert, ruby balls Ø1.100 mm					•	•		•	•
TEL75.7 298 000205 057	T-shaped measuring insert, ruby balls Ø1.350 mm					•	•		•	•
TEL75.8 298 000205 058	T-shaped measuring insert, ruby balls Ø1.650 mm					•	•		•	•
TEL75.9 298 000205 059	T-shaped measuring insert, ruby balls Ø2.050 mm					•	•		•	•
TEL75.10 298 000205 060	T-shaped measuring insert, ruby balls Ø2.550 mm					•	•		•	•
TEL75.11 298 000205 061	T-shaped measuring insert, ruby balls Ø3.200 mm					•	•		•	•
TEL75.12 298 000205 062	T-shaped measuring insert, ruby balls Ø4.000 mm					•	•		•	•



TELS



Alesta



H



HG



HPA



HPD



THV



LABC + P



LABCN

ACCESSORIES

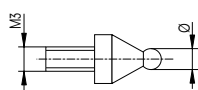
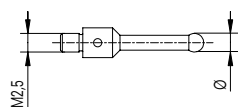

		TELS	ALESTA	H	HG	HPA	HPD	THV	LABC + P	LABCN
TEL76.2 509 05 20 0018	Measuring insert with ruby ball Ø0.5 mm					•	•		•	•
TEL76.3 509 05 20 0019	Measuring insert with ruby ball Ø1.0 mm					•	•		•	•
TEL76.4 509 05 20 0020	Measuring insert with ruby ball Ø2.5 mm					•	•		•	•
TEL76.5 509 05 20 0021	Measuring insert with ruby ball Ø5.0 mm					•	•		•	•
TEL77.100 279 901009 001	Pair of measuring inserts with ball Ø1.00 mm					•	•		•	•
TEL77.125 279 901009 008	Pair of measuring inserts with ball Ø1.25 mm					•	•		•	•
TEL77.150 279 901009 002	Pair of measuring inserts with ball Ø1.50 mm					•	•		•	•
TEL77.175 279 901009 009	Pair of measuring inserts with ball Ø1.75 mm					•	•		•	•
TEL77.200 279 901009 003	Pair of measuring inserts with ball Ø2.00 mm					•	•		•	•
TEL77.250 279 901009 004	Pair of measuring inserts with ball Ø2.50 mm					•	•		•	•
TEL77.300 279 901009 005	Pair of measuring inserts with ball Ø3.00 mm					•	•		•	•
TEL77.350 279 901009 006	Pair of measuring inserts with ball Ø3.50 mm					•	•		•	•
TEL77.400 279 901009 007	Pair of measuring inserts with ball Ø4.00 mm					•	•		•	•
TEL77.450 279 901009 010	Pair of measuring inserts with ball Ø4.50 mm					•	•		•	•
TEL77.500 279 901009 011	Pair of measuring inserts with ball Ø5.00 mm					•	•		•	•
TEL77.550 279 901009 012	Pair of measuring inserts with ball Ø5.50 mm					•	•		•	•
TEL77.600 279 901009 013	Pair of measuring inserts with ball Ø6.00 mm					•	•		•	•
TEL77.700 279 901009 014	Pair of measuring inserts with ball Ø7.00 mm					•	•		•	•
TEL77.900 279 901009 015	Pair of measuring inserts with ball Ø9.00 mm					•	•		•	•
TEL77.1000 279 901009 016	Pair of measuring inserts with ball Ø10.00 mm					•	•		•	•

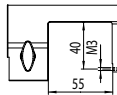
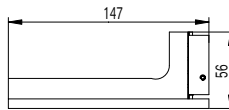
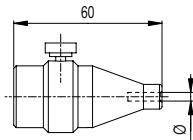
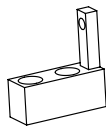
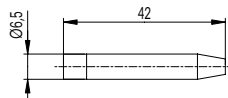

ACCESSORIES



		TELS	ALESTA	H	HG	HPA	HPD	THV	LABC + P	LBCN
TELS51 509 05 20 0027	Holder for measuring inserts M2.5	●						●		
TELS51E 509 05 20 0028	Holder for measuring inserts 4-48	●						●		
TELS51/D3.5 609 05 045	Pair of holders for measuring inserts Ø 3.5 mm	●						●		
TELS18 612 11 031	Pair of holders for measuring inserts Ø 3.5 mm	●								
TEL15 609 05 098	Pair of holders for measuring inserts Ø 3.5 mm			●	●	●	●		●	●
TEL5.0 612 11 017	Pair of holders for measuring inserts Ø 6.5 mm			●	●	●	●		●	●
TEL18 609 00 019	Pair of cone holder for int. thread measurement			●	●	●	●			
TEL16.2SP2 SP609 05 089 02	Pair of L-shaped holders for M3 Inserts					●	●		●	●
P25 276 950000 001	Electronic probe 25 mm	●						●		
P25TA 276 950001 001	Electronic probe P25 with magnetic insert	●						●		
P25TA.C 276 950001 002	Electronic probe P25 with magnetic insert, and certificate	●						●		
P25TA.1 279 950001 001	Magnetic insert for probe P25	●						●		
TA-MS-301 276 940001 004	Electronic probe 30 mm						●		●	
TA-MS-302 276 000230 001	Digital indicator 50 mm, resolution 0.001 mm	●		●	●	●	●	●	●	●
TEL3C.1 276 000230 002	Digital indicator 50 mm, resolution 0.01 mm	●		●	●	●	●		●	
TEL70 706 200 14	Electronic probe for internal measurement				●					
TULM70 706 200 13	Electronic probe for internal measurement					●				
LABC-70 706 203 01	Electronic probe for internal measure- ment, (with support, without interface)						●		●	

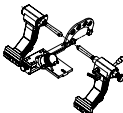
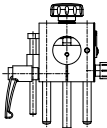
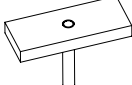
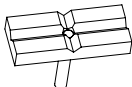
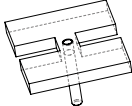
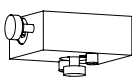
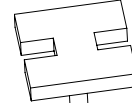
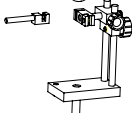
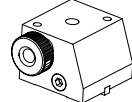
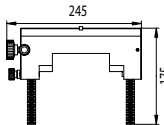

ACCESSORIES

		TELS	ALESTA	H	HG	HPA	HPD	THV	LABC + P	LABCN
	TA-MS-370 706 203 02									●
	LABC80 709 60 001						●		●	
	LABC80.1 712 04 003						●		●	
	TA-MS-381 712 04 010									●
	TA-MS-303 609 00 035					●				
	TA-SU-303 612 32 003					●				
	TELS5.1 602 33 004	●								
	TELS5.2 602 33 003	●								
	TELS5.3 602 33 001	●								
	TELS5 612 20 001	●								
	THV-101 602 33 002							●		
	THV-150 609 00 005							●		
	THV-100 602 15 001							●		
	TELMA7 602 39 007			●		●	●		●	●
	TELMA7/P 602 39 005			●		●	●		●	●

ACCESSORIES

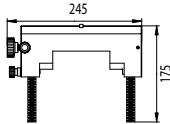
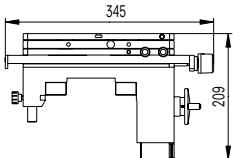
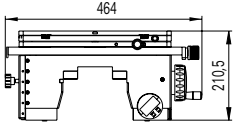
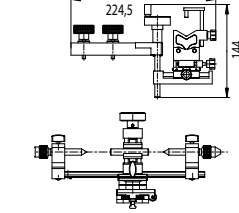
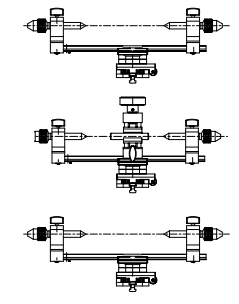
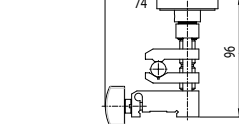
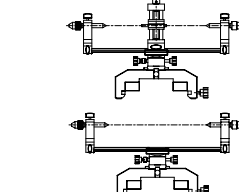
		TELS	ALESTA	H	HG	HPA	HPD	THV	LABC + P	LBCN
	TELMA7/SP04 602 39 012			•		•	•		•	•
	TELMA7/SP05 602 39 013			•		•	•		•	•
	HG-3 709 40 032				•					
	HG-3/P 609 40 032				•					
	TA-SU-313 709 40 044					•	•		•	
	H-13 709 40 018			•						
	HG-13 709 40 016				•					
	HPA-14 709 40 033					•	•		•	
	H-6 603 00 007			•						
	THV-115 709 40 035							•		
	THV-115.1 609 40 035							•		
	TA-SU-316 709 40 041					•	•		•	•
	TA-SU-317 609 40 041					•	•		•	•
	THV-115.2 706 04 002							•		
	LABC-15 709 40 034					•	•		•	
	LABC-15.1 609 40 034					•	•		•	

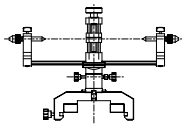
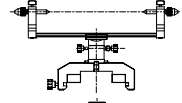
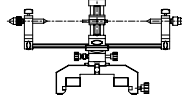
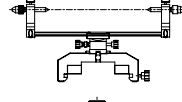
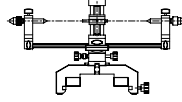
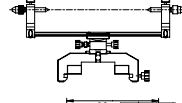
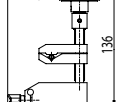
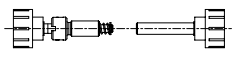
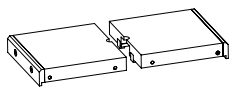
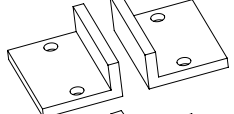
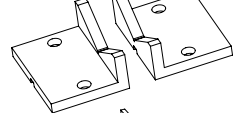
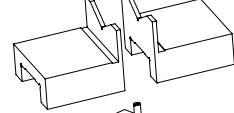
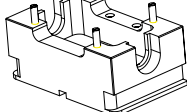

ACCESSORIES

		TELS	ALESTA	H	HG	HPA	HPD	THV	LABC + P	LABCN
	TA-SU-315 709 40 040									●
	Nano-15.1 609 40 040									●
	H-15 709 40 036			●						
	H-15.1 609 40 036			●						
	HG-15 709 40 037				●					
	HG-15.1 609 40 037				●					
	LABC-15.2 706 04 001			●	●	●	●		●	●
	LABC-15.3 708 03 007			●	●	●	●		●	●
	H-5 606 32 001			●						
	TELMN7.1 612 32 002			●		●	●		●	
	TELMN7.2 612 32 001			●	●	●	●		●	●
	TEL11 612 12 032			●		●	●		●	●
	TELMN7.2/SP01 612 23 001			●	●	●	●		●	

ACCESSORIES

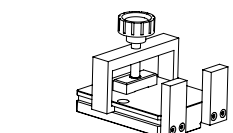
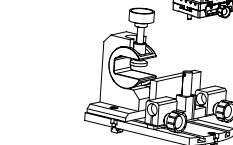
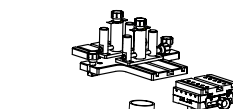
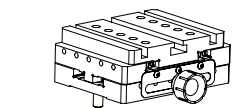
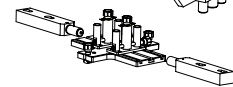
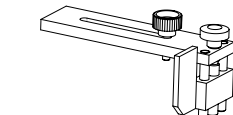
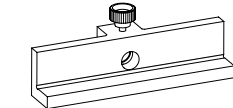
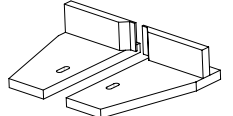
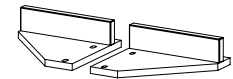
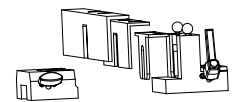
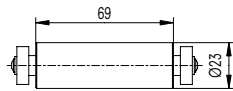
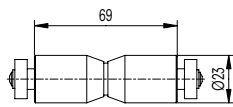
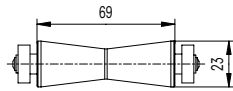







		TELS	ALESTA	H	HG	HPA	HPD	THV	LABC + P	LBCN
TELMN7.2/ SP02 613 07 006	V-shaped roll for cylindrical parts			•	•	•	•		•	
TELMN7.2/ SP03 613 07 007	Roll for Easy-Metric gauges			•	•	•	•		•	
TELMN7.2/ SP04 613 07 008	Cylindrical roll			•	•	•	•		•	
TA-SU-301 612 04 005	Supporting device for 2 points bore gauges			•	•	•	•		•	
TEL17 602 32 014	Pair of supporting plates for 2 points bore gauges <330 mm			•	•	•	•		•	
TEL17.2 602 32 016	Pair of supporting plates for 2 points bore gauges <180 mm			•	•	•	•		•	
TEL17.1 602 32 015	Supporting device for 2 points bore gauges				•					
TELMN4 602 20 013	Adjustable support for setting of reversal point			•	•	•	•		•	
TA-SU-305 709 60 003	Supporting device for gauge blocks 100-250 mm with anvils TA-MI-350					•	•		•	
TA-SU-306 612 04 008	Additional support for gauge blocks >250 mm, to be used with TA-SU-305, (to be mounted on TELMA7)					•	•		•	
TA-SU-307 709 60 004	Supporting device for gauge blocks (2 items): 1 support for gauge blocks 100-250 mm, 1 additional support for gauge blocks >250 mm									•
TULM14 708 209 140	Clamping device for external micrometers, 12-20 mm/.48"-4"					•	•		•	
TULM19 612 30 003	Holding device for depth calipers			•	•	•	•		•	

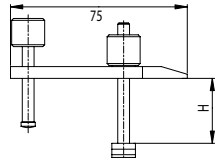
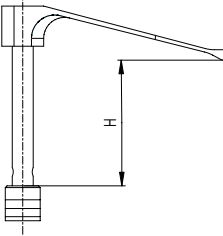

ACCESSORIES

		TELS	ALESTA	H	HG	HPA	HPD	THV	LABC + P	LABCN
	TEL5CN 612 02 008			●		●	●			
	TEL5CNE 612 02 007			●		●	●			●
	TULM5C 612 02 003					●	●		●	●
	TULM5CE 612 02 002					●	●		●	●
	TULM15 609 02 015					●	●		●	
	TEL14N 612 12 049					●	●		●	
	TA-SU-302 603 00 021					●	●		●	
	TEL10 612 12 023			●	●	●	●		●	
	TEL10E 612 12 022			●	●	●	●		●	
	LABC20 709 60 002					●	●		●	
	LABC20.1 609 60 002					●	●		●	
	THV-260 609 00 007								●	
	THV-261 609 00 006								●	
	TA-SU-304 SP609 60 001 01					●	●		●	●
	THV-180 606 25 008								●	
	THV-500 616 00 021								●	

ACCESSORIES

		TELS	ALESTA	H	HG	HPA	HPD	THV	LABC + P	LBCN
	TEL14.1 606 00 004			•	•	•	•		•	•
	TEL14.2 606 00 005			•	•	•	•		•	•
	TA-SU-354 706 02 004			•	•	•	•		•	•
	TA-SU-355 706 02 005			•	•	•	•		•	•
	TA-SU-356 706 02 006			•	•	•	•		•	•
	TA-SU-357 706 02 007			•	•	•	•		•	•
	TA-SU-358 706 02 008			•	•	•	•		•	•
	According to type		•							
	TA-SU-451 279 906001 028		•							
	TA-SU-407 279 906001 039		•							
	TA-SU-410 279 906001 073		•							
	TA-SU-411 279 906001 074		•							
	TA-SU-412 279 906001 075		•							
	TA-SU-419 279 906001 044		•							
	TA-SU-420 279 906001 069		•							
	TA-SU-483 279 906001 091		•							
	TA-SU-484 279 906001 092		•							



ACCESSORIES

		TELS	ALESTA	H	HG	HPA	HPD	THV	LABC + P	LABCN
	TA-SU-401 279 906001 051		●							
	TA-SU-402 279 906001 052		●							
	TA-SU-403 279 906001 053		●							
	TA-SU-405 279 906001 062		●							
	TA-SU-423 279 906001 089		●							
	TA-SU-404 279 906001 054		●							
	TA-SU-414 279 906001 063		●							
	TA-SU-417 279 906001 064		●							
	TA-SU-416 279 906001 065		●							
	TA-SU-418 279 906001 066		●							
	TA-SU-406 279 906001 070		●							
	TA-SU-421 279 906001 071		●							
	TA-SU-422 279 906001 072		●							
	TELS3.1C 279 918101 006	●								
	THV-181 601 01 002							●		
	THV-181E 601 01 001							●		

ACCESSORIES

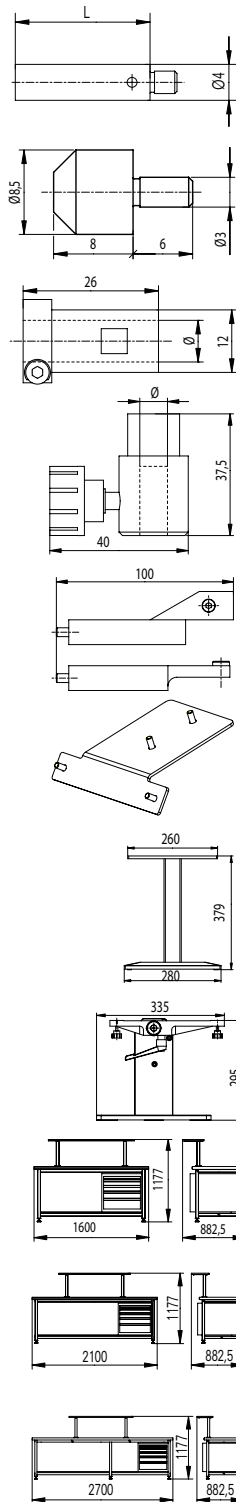

		TELS	ALESTA	H	HG	HPA	HPD	THV	LABC + P	LABCN
TEL76.6 501 04 20 0001	Extension for ball and T-shaped probes, L=7.5 mm						•		•	•
TEL76.7 501 04 20 0002	Extension for ball and T-shaped probes, L=15 mm						•		•	•
TEL76.1 512 12 20 0003	Holder for ball and T-shaped probes						•		•	•
TELS3C 603 12 002	Clamping sleeve for dial indicators Ø 8 mm	•								
TELS3CE 603 12 001	Clamping sleeve for dial indicators Ø3/8"	•								
TEL3.1 603 12 006	Clamping sleeve for dial indicators Ø 8 mm			•	•	•	•		•	
TEL3.1E 603 12 007	Clamping sleeve for dial indicators Ø3/8"			•	•	•	•		•	
TULM13.2 612 02 012	Dial indicator holder Ø8 mm for TA-SU-313, H-13, HG-13			•	•	•	•		•	
TULM13.2E 612 02 013	Dial indicator holder Ø3/8" for TA-SU-313, H-13, HG-13			•	•	•	•		•	
H-32 612 06 004	Printer holder for Horizon			•						
TULM30.1 612 05 002	Support for display unit Heidenhain ND287	•						•		
THV30.1 612 05 003	Support for display unit Heidenhain ND1100	•						•		
THV-200 712 12 038	Adjustable support							•		
LABC-TAB500 714 12 001	Table for horizontal instruments, Measuring range = 500 mm			•		•	•		•	
LABC-TAB1000 714 12 002	Table for horizontal instruments, Measuring range = 1000 mm			•		•	•		•	
LABC-TAB1500 714 12 003	Table for horizontal instruments, Measuring range = 1500 + 2000 mm			•		•	•		•	



ACCESSORIES

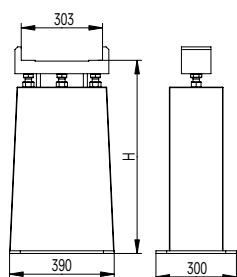

		TELS	ALESTA	H	HG	HPA	HPD	THV	LABC + P	LABCN
TELA05A/H700 602 13 004	Support for HG2000, H=700 mm				●					
TELA05A/H600 602 13 005	Support for HG3000, H=600 mm				●					
TELA05A/H500 602 13 006	Support for HG4000, H=500 mm				●					
TELA05A/H400 602 13 007	Support for HG5000, H=400 mm				●					
TELA05A/H300 602 13 008	Support for HG6000, H=300 mm				●					
TELA05A/H200 602 13 009	Support for HG7000, 8000 +10000, H=125 mm				●					
3P/0.17-3.2/S6.5 279 901004 101	Set of thread measuring wires with holders, Pitches 0.25-5 mm, holder bore Ø6.5 mm			●	●	●	●	●	●	●
TEL15/150 605 01 012	Set of probes for threads ISO 60°			●	●	●				
TEL15/152 605 01 013	Set of probes for threads Whitworth 55°			●	●	●				
TEL18/50S 605 01 010	Set of cones for internal thread measurement 60°			●	●	●				
TEL18/50ES 605 01 011	Set of cones for internal thread measurement 55°			●	●	●				
TEL75 605 01 009	Set of T-shaped measuring inserts with ruby balls				●	●	●		●	●
TEL76 605 01 004	Set of measuring inserts with ruby ball, for internal diameters >1 mm				●	●	●		●	●
TEL25D4M 609 01 002	Setting ring cones 60°			●	●	●				
TEL25D4E 609 01 001	Setting ring cones 55°			●	●	●				
TULM40D.INT 709 201 11	Master ring gauge Ø 40 mm with SCS certificate	●		●	●	●	●	●	●	●
TULM40INT.METAS 709 201 31	Master ring gauge Ø 40 mm with Metas certificate	●		●	●	●	●	●	●	●

ACCESSORIES

		TELS	ALESTA	H	HG	HPA	HPD	THV	LABC + P	LBCN
	TULM50D.EXT 709 201 01			•	•	•	•		•	•
	TULM50EXT. METAS 709 201 21			•	•	•	•		•	•
	TA-TO-004 290 000911 100			•	•	•	•		•	•
	TA-TO-003 290 000911 003			•	•	•	•		•	•
	TA-TO-302 514 02 20 0002			•	•	•	•		•	•
	TA-TO-301 514 02 20 0001	•						•		
	TA-TO-303 740 05 101	•		•	•	•	•	•	•	•
	TEL.HO500 505 05 10 0023			•		•	•		•	•
	TEL.HO1000 505 05 10 0024			•		•	•		•	•
	TEL.HO1500 505 05 10 0025			•		•	•		•	•
	TEL.HO2000 505 05 10 0026			•		•	•		•	
	TEL.HO3000 505 05 10 0027				•	•	•			
	TEL.HO4000 505 05 10 0028				•					
	TEL.HO5000 505 05 10 0029				•					
	TEL.HO6000 505 05 10 0030				•					
	TEL.HO8000 505 05 10 0032				•					
		TEL70.3 351 191 0001				•	•			



ACCESSORIES



		TELS	ALESTA	H	HG	HPA	HPD	THV	LABC + P	LABCN
	EL-D80S 351 292 0011	•						•		
	EL-D100S 351 292 0010	•						•		
	TA-DU-301 351 101 1001							•		
	TA-DU-302 351 101 1011				•	•				
	TA-DU-303 351 201 0012					•				
	TA-DU-330 351 192 0045				•	•				
	TELMA31 3706 0002			•			•	•	•	•
	TA-EL-301 3706 0009				•	•		•		
	TA-EL-040 358 0020									•
	TVM.O-PC/ AT.9P 333 9 0003						•		•	
	V-31 333 0 0003			•						
	CABL.RS.1/ 1-9P 332 01 0001			•						
	TA-EL-011 358 0006						•		•	•
	LABC-40 356 0010						•		•	•
	TA-EL-030 356 0016						•		•	•

ACCESSORIES

		TELS	ALESTA	H	HG	HPA	HPD	THV	LABC + P	LBCN
	V-30 356 0007			•						
	V-30.7 788 000001 001			•						
	TA-EL-001 332 10 0011			•			•		•	
	TA-EL-002 332 10 0013			•			•		•	
	TA-EL-003 332 10 0016			•			•		•	
	TA-EL-004 332 10 0014			•			•		•	
	TA-EL-005 616 20 003			•			•		•	
	TA-EL-131 334 0020			•						
	BAT-TVM.OPTO 3705 0002					•	•		•	
	TA-EL-331 740 16 002					•	•		•	
	TEMPCOMP-B 609 50 001						•		•	•
	TEMPCOMP-P 609 50 002						•		•	•
	TEMPCOMP-PA 609 50 003						•		•	•
	TEMPCOMP-PA DKD 609 50 004						•		•	•



ACCESSORIES

		TELS	ALESTA	H	HG	HPA	HPD	THV	LABC + P	LABCN
	TA-SW-001 394 1 0050			•	•	•		•		
	QM-MANAG 394 1 3201						•	•	•	•
	QM-CALIP 394 1 3202						•		•	•
	QM-DIAL 394 1 3203						•	•	•	•
	QM-MICRO 394 1 3204						•		•	•
	QM-PIN 394 1 3205						•	•	•	•
	QM-PLAIN 394 1 3206						•	•	•	•
	QM-BLOCK 394 1 3210						•	•	•	•
	QM-THREAD 394 1 3212						•	•	•	•
	QM-TTAP32 394 1 3214						•		•	•
	QM-SPLINE 394 1 3213						•		•	•
	QM-THREAD32 STARTER 394 1 3222						•	•	•	•
	QM-TTAP32 STARTER 394 1 3224						•		•	•
	QM-PACK32-1 394 1 3250						•	•	•	•
	QM-PACK32-2 394 1 3251						•	•	•	•

TWINNER



TWINNER

INTRODUCTION

TWINNER is a universal instrument for the measurement of cylinder-shaped parts, which replaces a great number of conventional instruments in the workshop. This measuring centre, multifunctional, flexible and mobile, allows to measure and document practically all that is manufactured by turning.

This instrument has been specifically developed for the workshop and lends itself perfectly to a use in production, close to the machining centre.

TWINNER allows the quality control of sole parts as well as that of small batches. Other areas of use are the control and acceptance of machine tool. All revolution parts can be precisely measured, without adjustment necessary. The range of parts that can be measured spreads over typical turning parts, such as axles, gearbox shafts, camshafts, crankshafts, transmission shafts, joints and revolving parts, to parts with very elaborate geometry.

TWINNER is available in the following dimensions: lengths of 400, 800, 1200 and 2000 mm and diameters of 125 or 160 mm. The manual use and control of the TWINNER are performed by a PC with TWINNER soft.

BUILT FOR WORKSHOP USE

VERY SIMPLE HANDLING

USE WITHOUT PRELIMINARY KNOWLEDGE

NO USER'S INFLUENCE THANKS TO A CONSTANT MEASURING FORCE

























EXCELLENT REPEATABILITY

VERY FAST CHANGE OF PART

EASY CALIBRATION

COMPLETE SELECTION OF ACCESSORIES

DESCRIPTION

- | | | |
|---|---|---|
|  Length |  External diameter |  Shoulder |
|  Diameter on odd division |  Width of internal recess |  Width of external recess |
|  Diameter of recess |  Width of chamfer |  Internal distance |
|  Internal depth |  Angle of taper |  Coaxiality |
|  Concentricity |  Axial run-out |  Interrupted axial run-out |
|  Axial run-out to part axis |  Position |  Radius |
|  Eccentricity |  Eccentricity to part axis |  Interrupted eccentricity |
|  Radial run-out to part axis |  Point of intersection |  Angular pitch |
|  Pitch | | |



Typical parts easily measured with a Twinner.

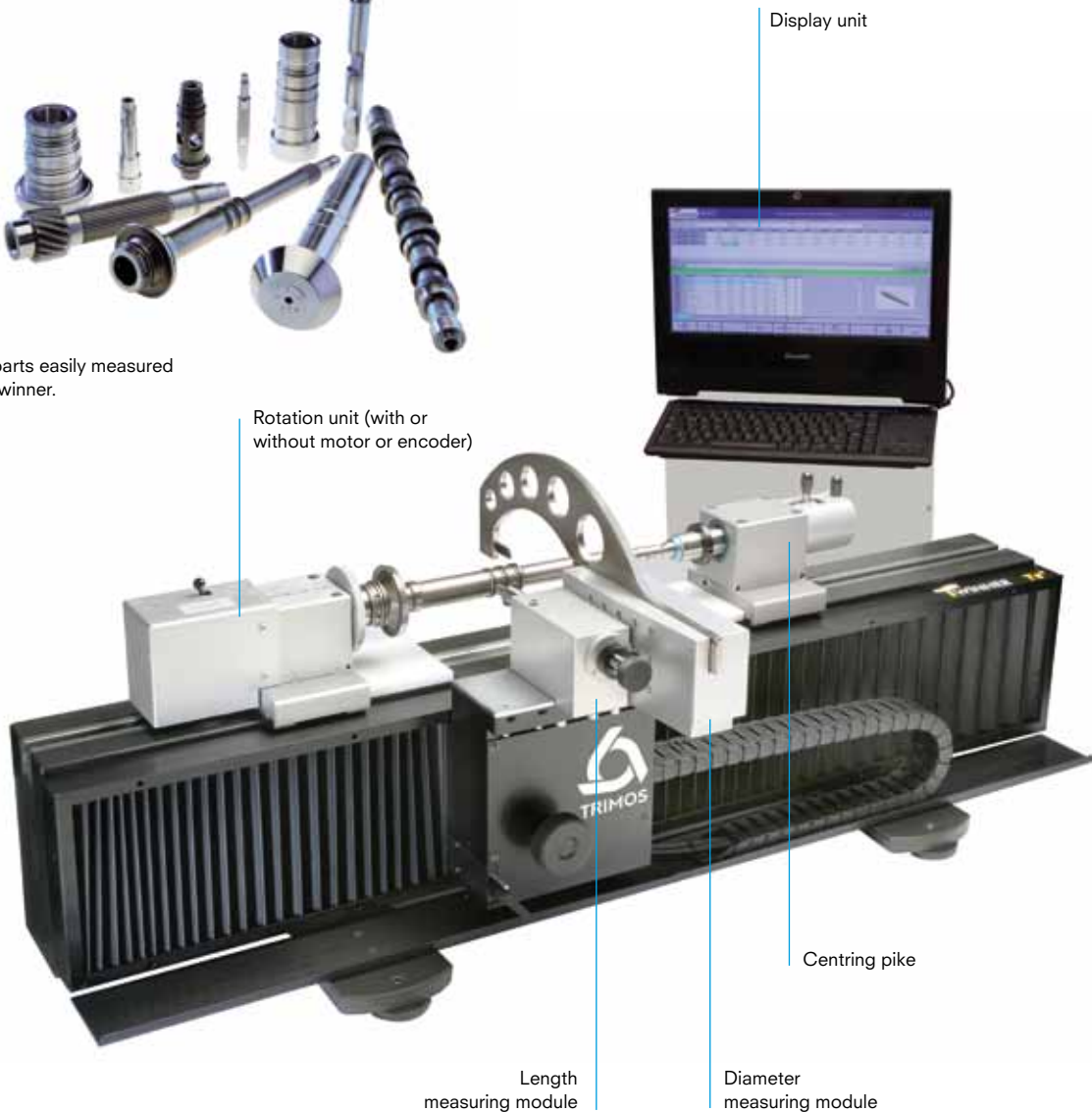

TWINNER

DISPLAY / SOFTWARE

The Twinner instruments are controlled by a PC system with different hardware and software modules:

- TWINNER master-easy
- TWINNER master-pro
- TWINNER premium-easy
- TWINNER premium-pro

HARDWARE

MASTER:

WITHOUT ENCODER, DIAMETER MODULE WITH 1 MEASURING SYSTEM

PREMIUM:

WITH ENCODER, DIAMETER MODULE WITH 2 MEASURING SYSTEMS

SOFTWARE

TWINNER SOFT EASY:

FREE MEASUREMENT (NO SEQUENCES)

MEASURING REPORTS

INDIVIDUAL MACROS

TWINNER SOFT PRO:

FREE MEASUREMENT

TEST SEQUENCES WITH USER GUIDE

TEACH-IN

STATISTIC

NETZWERKANBINDUNG

RECORDING OF RESULTS IN IN Q-DAS

MEASURING REPORTS

OPTICAL MODULE (OPTIONAL)

Ideal for the measurement of tiny details such as grooves, angles, chamfers etc.



DISPLAY / SOFTWARE

TWINNER SOFT PRO

For better comfort and more functionality, the TWINNER can be equipped with TWINNER soft Pro. This modern SPC system offers unbeatable value for money. Its flexibility makes it adaptable to the most diverse measuring situations.

- USE OF PROGRAM ADAPTED TO THE WORKSHOP

- MEASURING GRAPHICAL HELP

- MEASURING MACROS

- FREELY CONFIGURABLE VIEWS

- REPORTS AND MEASUREMENT GRAPHS

- MODERN AND CONVENIENT SPC SYSTEM

- FUNCTIONS ADMINISTRATION BY USERS AND PASSWORDS

- RECORDING OF RESULTS IN ASCII FORMAT IN Q-DAS



TWINNER Soft Pro considerably reduces the programming time of a measuring sequence and allows a rational use of the instrument.

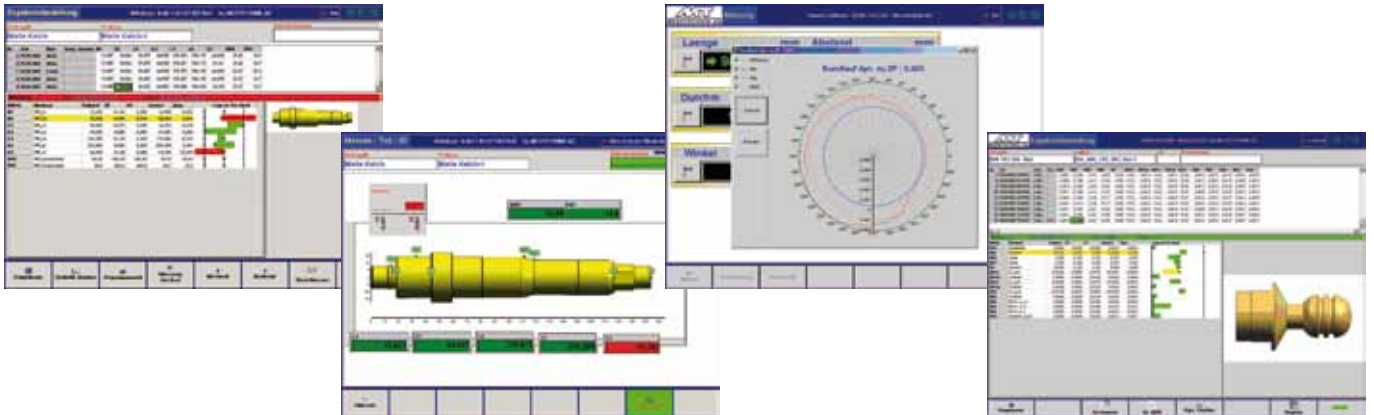

Numerous functions are integrated into the software:

- Freely configurable masks, reports and graphs
- Administration of functions by users and passwords
- Recording of results in ASCII format in Q-DAS



TWINNER

TECHNICAL SPECIFICATIONS

Twiner		T4M	T8M	T12M	T20M
Measuring range, length X	mm (in)	400 (15)	800 (31)	1200 (47)	2000 (78)
Measuring range, diameter Y	mm (in)	125 (5)	125 / 160 (5/6)		
Max. permissible errors, length X ¹⁾	µm	3 + L(mm) / 100			
Max. permissible errors, diameter Y ¹⁾	µm	1.5 + D(mm) / 100			
Repeatability, length X (2s) ¹⁾	µm	≤ 2.0			
Repeatability, diameter Y ¹⁾	µm	≤ 1.0			
Resolution, length X	mm	0.001 / 0.0001			
Resolution, diameter Y	mm	0.001 / 0.0001			
Measuring force, length and diameter	N	2.0			
Max. part weight	kg	20 / 100			
Weight (instrument)	kg	120	140	180	240

¹⁾ Values valid at temperature of 20 ± 0.2 °C and relative humidity of 50 ± 5%.

SCHEMA

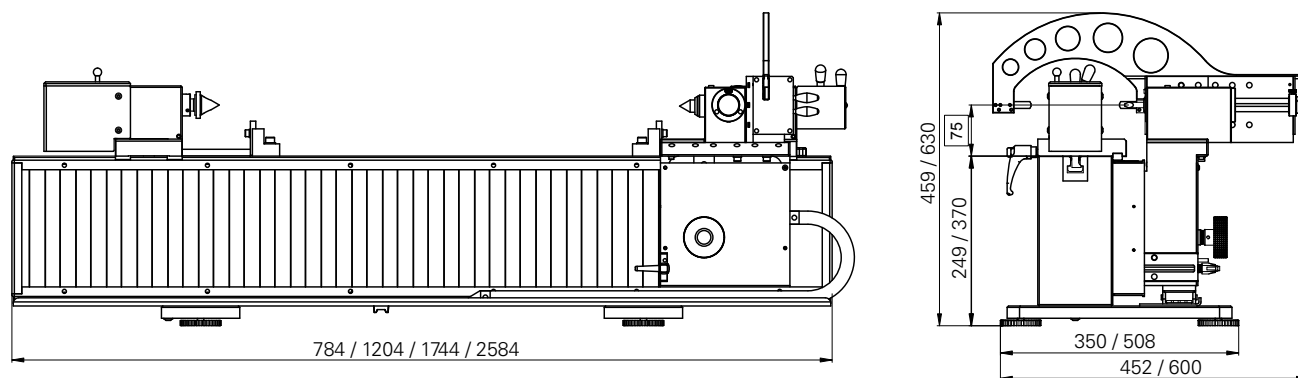

STANDARD INSTRUMENT

The Twinner instruments are supplied as follows:

- Instrument according to specifications
- PC with corresponding hardware and software equipment (see next page)
- User's manual
- Test certificate
- Declaration of conformity

CODE NUMBER

Twiner	PC equipment
T4 Master-Easy 700 215 10 12	Twiner T4 without encoder, 1x Diameter-Modul, free measurement
T4 Master-Pro 700 215 10 13	Twiner T4 without encoder, 1x Diameter-Modul, Sequences
T4 Premium-Easy 700 215 10 14	Twiner T4 with encoder, 2x Diameter-Modul, free measurement
T4 Premium-Pro 700 215 10 15	Twiner T4 with encoder, 2x Diameter-Modul, Sequences
T8 Master-Easy 700 215 20 12	Twiner T8 without encoder, 1x Diameter-Modul, free measurement
T8 Master-Pro 700 215 20 13	Twiner T8 without encoder, 1x Diameter-Modul, Sequences
T8 Premium-Easy 700 215 20 14	Twiner T8 with encoder, 2x Diameter-Modul, free measurement
T8 Premium-Pro 700 215 20 15	Twiner T8 with encoder, 2x Diameter-Modul, Sequences
T12 Master-Easy 700 215 30 12	Twiner T12 without encoder, 1x Diameter-Modul, free measurement
T12 Master-Pro 700 215 30 13	Twiner T12 without encoder, 1x Diameter-Modul, Sequences
T12 Premium-Easy 700 215 30 14	Twiner T12 with encoder, 2x Diameter-Modul, free measurement
T12 Premium-Pro 700 215 30 15	Twiner T12 with encoder, 2x Diameter-Modul, Sequences
T20	Twiner T20 (on request, other models T16, T25, etc.)

The models above are supplied with granite base and PC for corresponding measuring systems and software. Diameter modules, length modules, measuring inserts, location centers etc. must be selected separately from the accessory list.

SPECIFIC MODELS

Trimos offers specific solutions adapted to all applications for measurement of cylinder-shaped parts and revolving parts. For more information, your local Trimos agent remains at your disposal.



TWINNER

APPLICATIONS



Centerline measurement



Length measurement

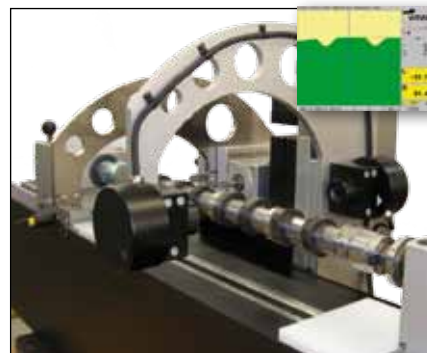

Optical measurement of the characteristics of a camshaft

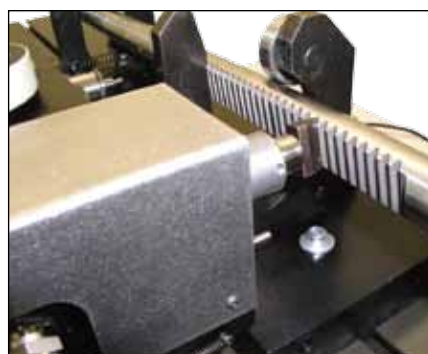

Measurement of rack rail teeth inclination (specific design)

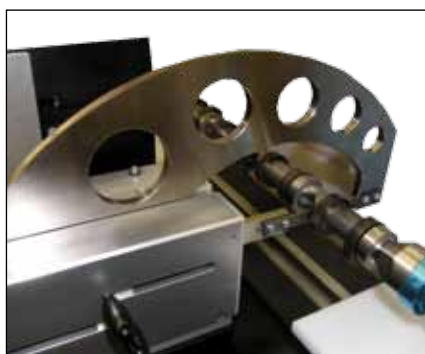

Diameter measurement on a camshaft



Diameter measurement in a groove



Positions measurement (specific design)





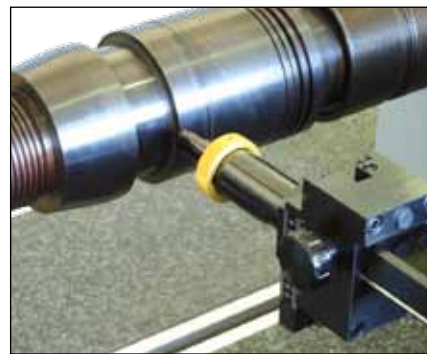











Installation for eccentric diameter measurement (specific design)



Length measurement for large parts (specific design)













ACCESSORIES

			Twinner
	TA-MI-501 279 953322 251	Insert for diameters - Knife-shaped	•
	TA-MI-503 279 953322 259	Special insert for diameters, $\text{Ø}10\div\text{Ø}135$ mm	•
	TA-MI-507 279 953322 280	Special insert for diameters with step	•
	TA-MI-502 279 953322 263	Insert for diameters - 4 x 0.8 mm	•
	TA-MI-515 279 953322 241	Probing axis, type E	•
	TA-MI-516 279 953322 255	Insert for length, type E	•
	TA-MI-530 279 953322 268	Measuring insert with ball $\text{Ø}1.5$ mm for axial run-out to part axis module	•
	TA-MI-517 279 953322 271	Insert for length, for position of wholes	•
	TA-MI-521 279 953322 272	Measuring insert for position of wholes	•
	TA-IH-510 279 953322 273	Insert for length, $\text{Ø}=4/8$ mm without probe	•
	TA-IH-530 279 953322 275	Probe holder for cylinders $\text{Ø}=2$ mm	•
	TA-MS-502 275 953322 202	Diameter module $\text{Ø}<125$ mm, without probe, 2 measuring systems	•
	TA-MS-503 275 953322 203	Diameter module $\text{Ø}<160$ mm, without probe, 1 measuring system	•
	TA-MS-501 275 953322 208	Diameter module $\text{Ø}<125$ mm, without probe, 1 measuring system	•



Twiner

ACCESSORIES

			Twiner
	TA-MS-504 275 953322 209	Diameter module $\varnothing < 160$ mm, without probe, 2 measuring systems	•
	TA-MS-510 275 953322 204	Length measuring module, without probe for T4M/T8M/T12M	•
	TA-MS-511 276 953322 001	Length module with 3D probe, for PC	•
	TA-MS-530 275 953322 206	Length, run-out measuring module, without probe	•
	TA-MI-531 279 953322 276	Probe for L Module M2.5 D=2mm	•
	TA-MI-532 279 953322 277	Probe for L Module M2.5 D=3mm	•
	TA-MS-551 352 0032	T-CAM package - vision system with motorized Z axis, 1 MS, 70/D125	•
	TA-MS-552 352 0037	T-CAM package - vision system with motorized Z axis of 70 mm/D 160 mm	•
	TA-MS-540 271 953322 251	Encoder for rotating system (11 μ A)	•
	TA-MS-541 271 953322 252	Encoder for rotating system (1Vss)	•
	TA-AD-528 249 953322 203	Uni- rotating system empty 100 Kg, incl. protection T with motor and encoder	•
	TA-SU-520 249 953322 052	Rotating location center 60°/D=18 mm XN-2	•
	TA-SU-521 249 953322 062	Rotary location center 60°/Ø42 mm	•















ACCESSORIES

			Twinner
	TA-SU-523 249 953322 069	Rotary anvil 60°/D=18 mm	•
	TA-SU-527 249 953322 068	Rotary location center 60°/Ø42 with opening	•
	TA-SU-510 249 953322 053	ZP- Fixing 60°/D=18 mm, HM	•
	TA-SU-511 249 953322 055	Location center 60°, D=18 mm	•
	TA-SU-515 249 953322 056	ZP-fixed location centers 60°/D=18mm long	•
	TA-SU-512 249 953322 064	ZP-Location center 60° D=1-42 mm Long	•
	TA-SU-518 249 953322 073	ZP-Location center 60° D=16-68 mm Long	•
	TA-SU-517 249 953322 065	Rotary anvil 60°/D=25 mm with reference ring D=40mm/B=4mm	•
	TA-SU-513 249 953322 060	ZP-Location center 60° D=29 mm with reference ring D=39mm L=6 mm	•
	TA-SU-516 249 953322 061	ZP-fixed location center 52° D=29 mm with reference ring D=39mm L=6 mm	•
	TA-SU-530 249 953322 101	WST-V support width = 30 mm D=3-45 mm	•
	TA-SU-537 249 953322 109	WST-V support width = 30 mm D=3-45 mm	•
	TA-SU-531 249 953322 102	WST-V supports width = 18 mm D=3-45 mm	•
	TA-SU-538 249 953322 110	WST-V supports width = 18 mm D=3-45 mm	•



Twiner

ACCESSORIES

			Twiner
	TA-SU-532 249 953322 103	WST-adjustable V D=18 mm-60 mm	•
	TA-SU-533 249 953322 104	WST-adjustable V D=20 mm - 70 mm	•
	TA-SU-536 249 953322 105	WST-adjustable V D=17 mm-D=107 mm	•
	TA-SU-534 249 953322 106	WST-adjustable V D=20-70mm-H=100mm D=125mm	•
	TA-SU-535 249 953322 107	WST-adjustable V D=20-70mm-H=100mm D=160mm	•
	TA-AD-522 249 953322 002	Manual location center, fixed, 20 kg, incl. T-Protection	•
	TA-AD-523 249 953322 003	Manuel location center, fixed, 100 kg, incl. T-Protection	•
	TA-AD-524 249 953322 004	Fixed location center 20 kg, incl. protection T	•
	TA-AD-526 249 953322 006	Duo location center	•
	TA-AD-525 249 953322 005	Fixed location center 100 kg, incl. protection T	•
	TA-AD-527 249 953322 201	Uni- rotating system empty 20 kg, incl. T protection	•
	TA-AD-502 279 953322 261	Adjustable ring, M 2.5, without probe	•
	TA-SU-501 239 953322 251	Handle for universal rotating system	•
	TA-SU-502 238 953322 251	Drive system for universal rotation system	•





ACCESSORIES

		Twiner
	TA-AD-501 279 953322 242 Revolver system for L-Modul	•
	TA-AD-514 249 953322 900 Z module adapter plate for center height 100 mm for Ø10÷Ø170	•
	TA-AD-511 249 953322 903 Adapter plate for centers 10/20 Kg T16/T20/T25 D 160/H 100 mm	•
	TA-AD-510 249 953322 904 Adapter plate for centers 10/20 Kg T4/T8/T12 D 160/H 100 mm	•
	TA-AD-512 249 953322 907 Adapter plate for centers 100 Kg T4/T8/T12 D 160/H 100 mm	•
	TA-AD-513 249 953322 908 Adapter plate for centers 100 Kg T16/T20/T25 D 160/H 100 mm	•
	TA-AD-504 275 953322 903 Adapter plate for L-Module T16/T20/T25 D160/H100	•
	TA-AD-503 275 953322 904 Riser plate for L-Module T4/T8/T12 D160/H100	•
	TA-MG-511 278 953322 001 L- axis for calibration in wodden box	•
	TA-MG-510 278 953322 002 L-reference axis in wooden box	•
	TA-MG-501 278 953322 003 D-Reference axis D=125mm in wooden box	•
	TA-AD-508 295 953322 001 Support for screen Twiner Cable CH	•
	TA-AD-509 295 953322 002 Support for screen Twiner Cable De	•
	TA-TO-501 286 953322 001 T groove protection	•



Twiner

ACCESSORIES

			Twiner
	TA-AD-505 279 953322 274	Protection for HM-Knife Probe	•
	TA-TO-550 280 953322 002	Packaging system with case T4M and T8M/D125	•
	TA-TO-551 280 953322 003	Packaging system with case T8M and T12M/D160	•
	TA-TO-510 290 953322 001	Tool and cleaning set	•
	TA-SW-501 394 1 2002	Option TWINNERSoft for measurement according to program	•

TR Profile + DH-8



TR Profile + DH-8

INTRODUCTION

The TR Profile and TR Profile DH-8 are extremely precise surface roughness measuring instruments, built for the use in the workshop and on production lines as well as in the lab.

From the simple roughness measurement without accessories, directly on the machine, to the measurements in the laboratory with measuring support, special tracers and other accessories, including the recording of contours, the TR Profile and TR Profile DH-8 offer maximum flexibility for surface analysis.

The tracers are the core pieces of the roughness meters. They are, to a wide extent, the determining factor of the precision of the measuring values obtained. The great choice of tracers is the result of decades of experience in the construction of such probes. The traversing unit with an integrated reference flat allows to effect precise measurements also with skidless tracers (VHF versions). The traversing units of TR Profile and TR Profile DH-8 are identical.

All instruments can be connected to a PC. They are delivered with a simple analysis software.

LINEARITY AND MEASURING ACCURACY

APPLICATION FLEXIBILITY

LARGE RANGE OF ACCESSORIES

REMOVABLE TRAVERSING UNITS

RECHARGEABLE BATTERY FOR MOBILE APPLICATIONS

TRACERS WITH AND WITHOUT SKID

EASE OF USE

DESCRIPTION



USB interface for connection with PC

INTERCHANGEABLE TRACERS
With skid: version VH
With and without skid: version VHF

TRAVERSING UNIT
integrated in the instrument, can also be connected with a cable to the instrument for measurement with stand or to reach difficult measuring points



INTEGRATED PRINTER
For parameters, Profiles and bearing ratio

USB interface for connection with PC



INTERCHANGEABLE TRACERS
With skid: version VH
With and without skid: version VHF

TR Profile + DH-8

DISPLAY / SOFTWARE

TR PROFILE

Extremely simple and intuitive use. Only 4 buttons to access to all functions.

Parameters:

ISO/DIN: Ra, Rz (DIN), Rmax, R3z, Rt, Rq (RMS), Rk, Rp, Rv, Rpk, Rvk, MR1, MR2, Rpc, C1, C2, bearing ratio Rmr, C0, Cz
 JIS: Ra (JIS), Rz (JIS)
 ISO 12085: R, AR, Rx

DISPLAY OF PARAMETERS AND PROFILES

MEMORY FOR 15 MEASURING PROFILES

AUTOMATIC CALIBRATION

CUT-OFF FIRMLY ASSIGNED TO THE TRAVERSING LENGTH

USB DATA OUTPUT

MENUS IN 6 DIFFERENT LANGUAGES



TR PROFILE DH-8

Multifunctional and polyvalent measuring instrument for roughness and contour measurement.

Parameters:

ISO/DIN: Ra, Rz (DIN), Rmax, R3z, Rt, Rq (RMS), Rk, Rp, Rv, Rpk, Rvk, MR1, MR2, Rpc, C1, C2, bearing ratio Rmr, C0, Cz
 JIS: Ra (JIS), Rz (JIS)
 ISO 12085: R, AR, Rx

DISPLAY OF PARAMETERS AND PROFILES

MEMORY FOR 50 MEASURING PROFILES

AUTOMATIC CALIBRATION

5 MEASURING LENGTHS, ALL SELECTABLE BETWEEN 0.5 AND 15.0 MM

MEASURING SPEED SELECTABLE

CALIBRATION FOR MAX. 8 TRACERS

8 MEASURING PROGRAMS

TOLERANCE INDICATION

KEY LOCK FOR LT, LC AND R TO PREVENT ANY SETTINGS MISTAKES

USB OUTPUT FOR DATA TRANSFER (OPTION: BLUETOOTH)

CONTOUR MEASUREMENTS

MENUS IN 6 DIFFERENT LANGUAGES



TR Profile + DH-8

TECHNICAL SPECIFICATIONS

		TR Profile	TR Profile DH-8
Measuring range (Ra, Rq)	µm	20	
Measuring range (other parameters)	µm	350	
Measuring range of tracers	µm	350	
Max. permissible errors Ra	%	5%	
Repeatability (Ra, 1σ)	µm	0.009	
Resolution (Ra, Rq)	µm	0.01 (<0.1 µm: 0.001)	
Resolution (other parameters)	µm	0.1	
Vertical resolution of tracers	µm	0.01	
Horizontal resolution of tracers	µm	1	
Measuring speed	mm/s	0.5	0.25/0.5/1.0
Measuring force, tracers with skid	N	< 0.15	
Measuring force, tracers without skid	mN	< 0.5	
Diamond tip radius	µm	5 µm, 90° (standard) or 2 µm, 60° (option)	
Cutoffs lc	mm	0.08/0.25/0.8/2.5	
Measuring lengths lt	mm	0.48/1.50/4.8/15.0	0.5 ÷ 15 (programmable)
Relative humidity	%	20 ÷ 80	

Contour Tracer (TA-MS-650)			
Horizontal measuring range (X)	mm	15	
Vertical measuring range (Z)	mm	4	
Max. permissible errors (Z)	µm	5	
Tracing angle: rising flanks	°	< 77	
Tracing angle: falling flanks	°	< 88	

DIAGRAM

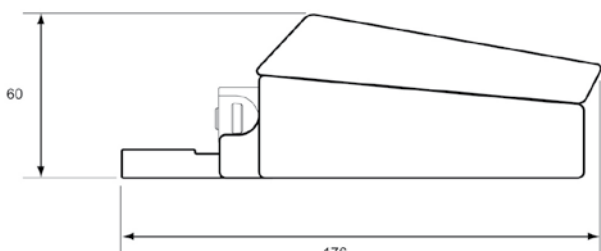
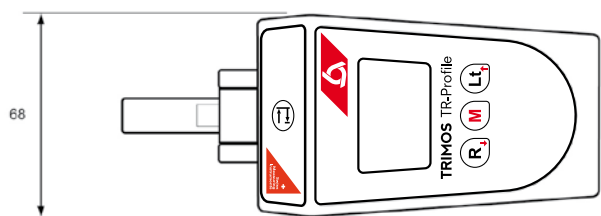

TR Profile

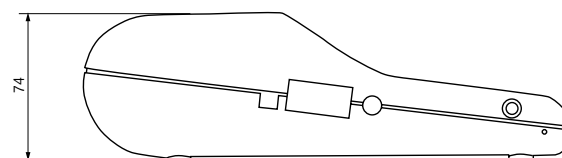
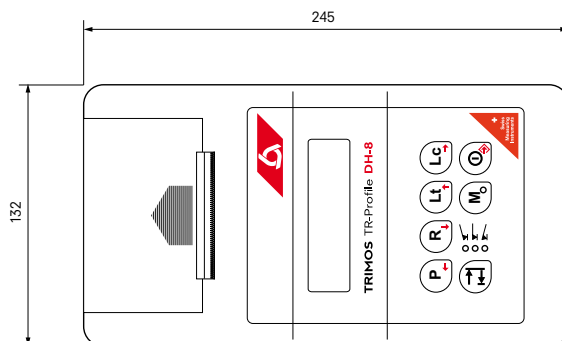

TR Profile DH-8

STANDARD INSTRUMENT

The TR Profile instruments are supplied as follows:
Instrument according to specifications
Traversing unit VH or VHF
Standard tracer (TA-MS-601)
Adapter with connecting cable (TA-EL-601)
Roughness standard, Ra=3.0 µm (TA-MG-609)
Charging unit
USB cable
Screw driver
User's manual (750 50 0040 03) and quick guide (750 50 0036 03)
Certificate of quality
Software DIASOFT Basic (TA-SW-601)
Carrying case

The TR Profile DH-8 instruments are supplied as follows:
Instrument according to specifications
Traversing unit VH or VHF
Standard tracer (TA-MS-601)
Roughness standard, Ra=3.0 µm (TA-MG-609)
Charging unit
USB cable
Screw driver
User's manual (750 50 0042 00) and quick guide (750 50 0043 03)
Certificate of quality
Software DIASOFT Basic (TA-SW-601)
Carrying case

CODE NUMBER

TR Profile	TR Profile DH-8	
TR Profile VH 700 401 10 01	TR Profile DH-8/VH 700 401 10 51	For tracers with skid
TR Profile VHF 700 401 10 02	TR Profile DH-8/VHF 700 401 10 52	For tracers with and without skid
	TR Profile DH-8/VHF-CP-S 700 401 10 61	Set for contour measurements Simple - TR Profile DH-8/VHF - Contour tracer (TA-MS-650) - Contour standard (TA-MG-651) - Software DIASOFT Standard (TA-SW-602) - Contour module Simple (TA-SW-610)
	TR Profile DH-8/VHF-CP-A 700 401 10 62	Set for contour measurements Advanced - TR Profile DH-8/VHF - Contour tracer (TA-MS-650) - Contour standard (TA-MG-651) - Software DIASOFT Standard (TA-SW-602) - Contour module Advanced (TA-SW-611)

TR Profile + DH-8

APPLICATIONS



Checking of surface roughness near a shoulder (TA-MS-601)

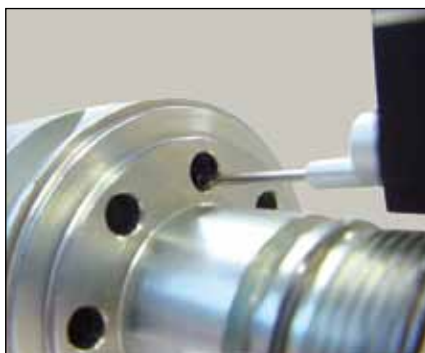

Measurement in small bores (TA-MS-605)



Measuring surface roughness of a polished part (TA-MS-607)



Checking at recessed measuring points (TA-MS-609)

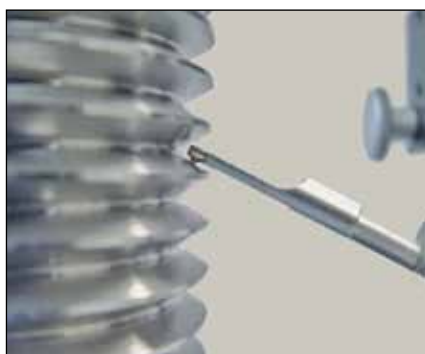

Checking of thread profile roughness of a thread plug gage (TA-MS-620)

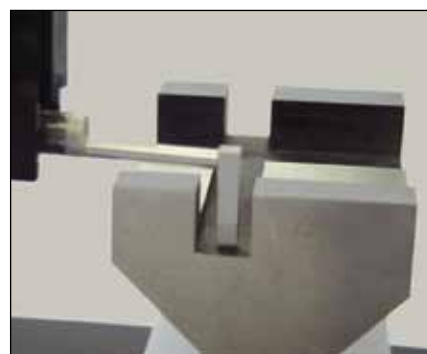

Checking in a recess using an appropriate probe (TA-MS-608)



Radial roughness measurement (TA-MS-621)



Transversal flank measurement (TA-MS-627)



Contour measurement with TR Profile DH-8/VHF (TA-MS-650)

TR SCAN



TR SCAN

INTRODUCTION

The TR Scan offers an innovative alternative to classical surface measurement. Its modular concept, allowing adaptation to each application, and its simple use, make it very efficient in the workshop. Because of its simplicity of use, the TR Scan can be operated by workshop personnel to get reliable results secured with minimum training. All measured surfaces can be treated according to current international standards such as ISO, DIN, JIS, ASME, CNOMO etc., as well as the upcoming ISO 25178 3D standard.

The TR Scan is completely designed and manufactured in Switzerland according to the highest quality standards. Robustness, reliability and longevity are part of our tradition. Trimos instruments have been used in workshops and labs for over 30 years.

The interchangeability of the measuring heads gives the possibility to select the most appropriate technology for each application. This flexibility allows the characterization of surfaces in numerous application fields, such as mechanical industry (all types of machined surfaces), car and aerospace industries, photovoltaics, as well as plastics, papers, imprints, fibrous materials, wood, abrasives, paint, cosmetics, etc.

MEASURING RESULTS FULLY COMPARABLE TO
CLASSICAL SYSTEMS

COMPLIES TO ALL INTERNATIONAL STANDARDS

INTUITIVE, EASY TO USE INTERFACE

ROBUST INDUSTRIAL SYSTEM FOR THE WORKSHOP

POSSIBLE AUTOMATED MEASUREMENTS

MODULAR AND COMPACT CONCEPT

MEASUREMENT AND ANALYSIS WITHIN SECONDS

DESCRIPTION

AUTOMATED Z-AXIS

Motorized axis allow for precise and automated measurements. The working distance is automatically worked out by the system.



INTERCHANGEABLE MEASURING HEADS

The unique system of interchangeable measuring heads confers a high degree of adaptability to every application. Changing a head is quickly done and automatically recognized by the system. Several technologies are available for complete application coverage.

TRIMOS NANOWARE MEASURE

Software for the management of all measurement parameters

TRIMOS NANOWARE ANALYSIS

Software for the analysis of measured surfaces



Motorized table (XY)

TR SCAN

DISPLAY / SOFTWARE

TRIMOS NANOWARE MEASURE

This exclusive software allows the handling of the instrument (positioning and configuration of all measurements).

Positioning in X,Y,Z is performed either automatically by pre-defined parameters or via the use of an intuitive joystick aided by a integrated positioning laser and a camera (optional).

Once positioned, measurements are taken automatically with one click or via the use of a manual size parameter in a few seconds.

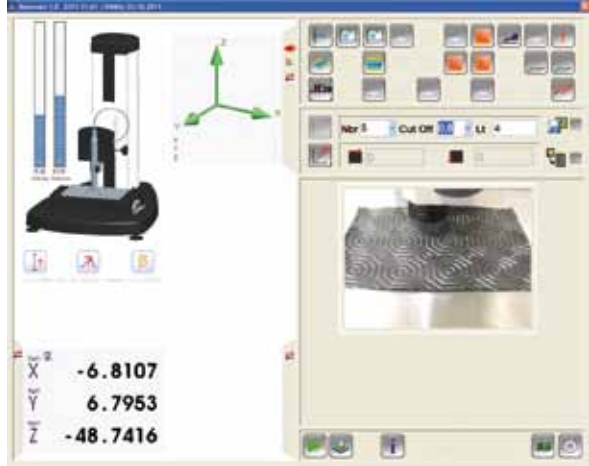

INTUITIVE POSITIONING

INSTANT MEASUREMENT

PROGRAMMABLE MEASUREMENTS WITH PICTURE

TRIMOS NANOWARE ANALYSIS

This software allows the analysis of all measured surfaces according to current international standards such as ISO, DIN, JIS, ASME, CNOMO etc., as well as the 3D standard ISO 25178.

Analysis can be performed automatically by the use of a template, or the user can have direct access to the raw data. The incorporated analysis software is powered by Mountains®, the most powerful and recognized 2D/3D surface analysis software available.

Reports are automatically generated during analysis. Any report can be used as a template later.

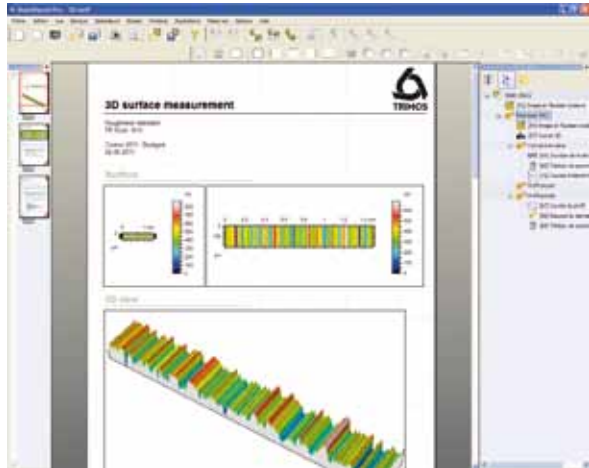

POWERFUL ANALYSIS

PROFESSIONAL REPORTING

SUITABLE MODULE FOR EACH APPLICATION NEED

COMPLIES TO ALL INTERNATIONAL STANDARDS



THE CCM TECHNOLOGY

Chromatic Confocal Microscopy (CCM) has been acknowledged worldwide as an accurate and reliable technique for non-contact surface measurement. A chromatic lens L generates the image of a point white-light source W as a continuum of monochromatic images located on the optical axis ("Chromatic coding"). A sample O is located inside the color-coded segment and its surface scatters the incident light beam. The backscattered light passes through the chromatic lens L in the opposite direction, and arrives at a pinhole P which filters out all wavelengths except a single wavelength, λ_M . The collected light is analysed by a spectrometer S. The sample position is directly related to the detected wavelength.

- High resolution
- Works on all types of sample materials
- Wide choice of measuring ranges
- Steep slope compatibility
- Coaxial (no shadowing)
- Recognised method by ISO 25178

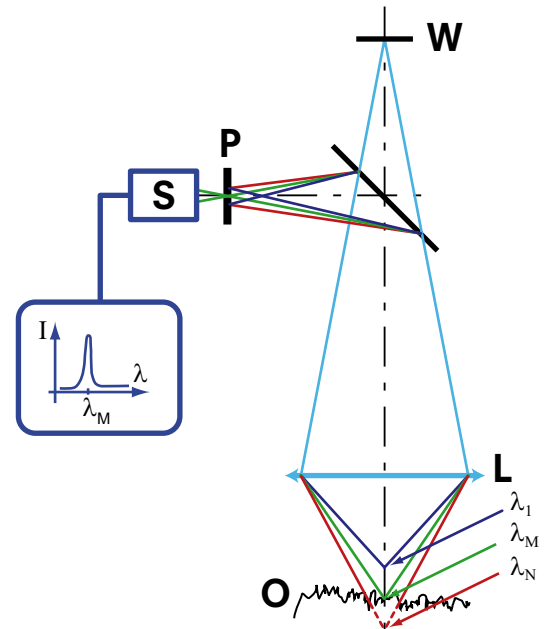

CCM P1 MEASURING HEAD



CCM-P1
(support & spectrometer)

TA-MI-701 ÷ 713
Optical pen

COMPLEMENTARY TECHNOLOGIES

There is no universal technology for surface measurement. The modularity of the TR Scan allows the use of the best adapted head for each application.

The diagram here below shows the application field of the TR Scan and of its various measuring heads according to the material structure.

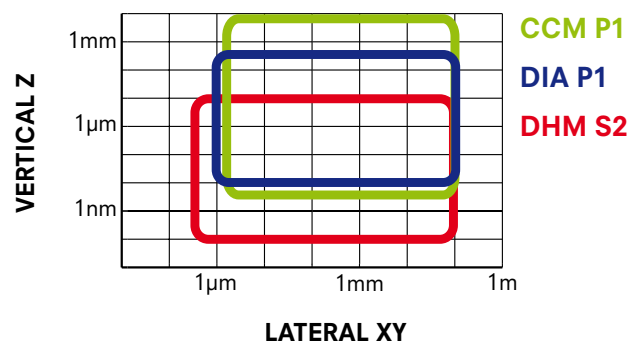

TR SCAN

MEASURING HEADS

DHM S1 & S2

DHM Technology:

- Smooth, grinded and polished surfaces
- Steel, aluminium, titanium, silicon, gold, ceramics, glass
- High precision and speed, 2D/3D

CCM P1

Chromatic Confocal Technology:

- Machined and rough surfaces, micro-structures
- Metals, plastics, abrasives, papers, textiles, cosmetics
- Large vertical range, all materials, 2D/3D

DIA P1

Diamond Stylus Tip Technology:

- Roughness measurement with contact
- Classical roughness measurements (2D)
- Internal measurements

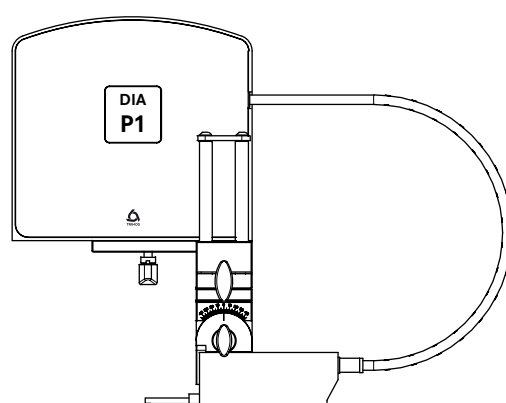
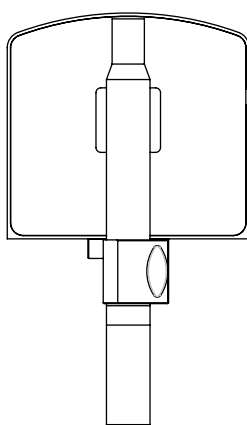
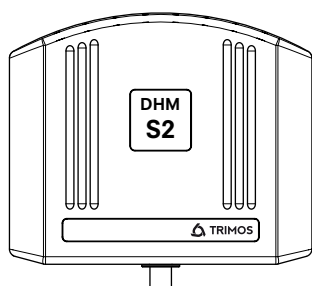

TECHNICAL SPECIFICATIONS

TR Scan		101	201	301
Horizontal measuring range X	mm	-	100	100
Horizontal measuring range Y	mm	-	-	100
Vertical measuring range Z	mm		240	
Measuring system resolution XYZ	µm		0.1	
Positioning accuracy XYZ	µm		1	
Rectitude of the guideways XY	µm		1.5	
Max weight of the part	kg		20	

Measuring heads		DHM S1	DHM S2	CCM P1	DIA P1
Vertical resolution (Z)	nm	1	1	8 ÷ 22 ²⁾	10
Lateral resolution (XY)	µm	0.6	0.6	0.9 ÷ 3.5 ²⁾	1
Typical measuring range Ra ¹⁾	µm	0.4	1.6	>200 ²⁾	20
Vertical measuring range ¹⁾	µm	3	7	130 ÷ 400 ²⁾	350
Max. permissible errors Ra	%	1%	1%	1% ÷ 5% ²⁾	5%
Repeatability (Ra, 1σ)	nm	< 0.1	< 0.1	<5 ÷ 20 ²⁾	9
Sample reflectivity	%	< 1% ÷ 100%	< 1% ÷ 100%	1% ÷ 100%	-
Field of view	mm	0.25 x 0.25	0.25 X 0.25	-	-

¹⁾ Values may differ depending on the surface texture

²⁾ Objective dependent

DIAGRAM

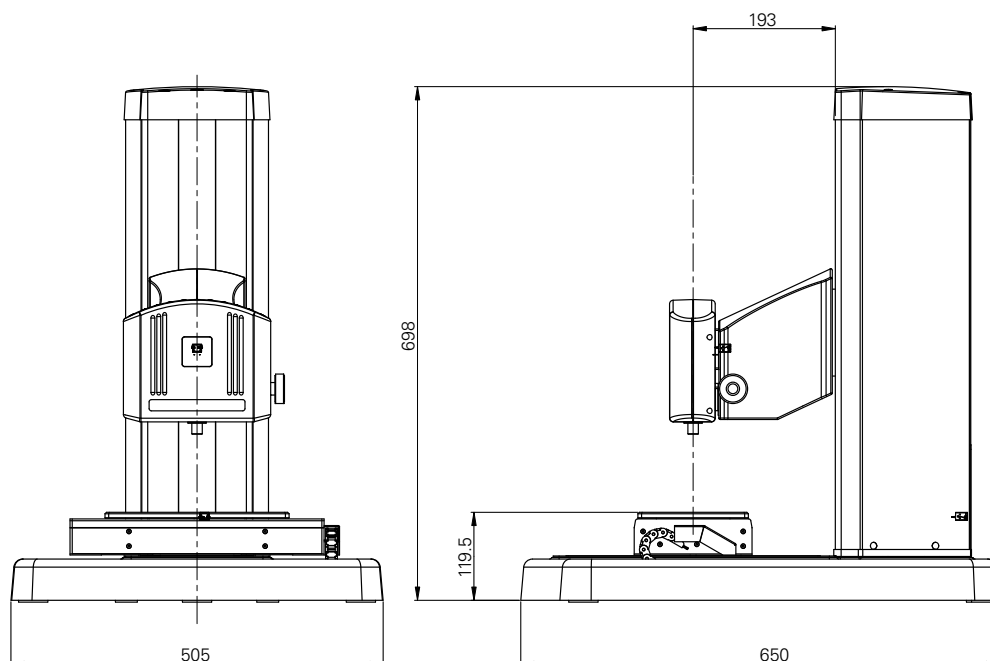

STANDARD INSTRUMENT

The TR Scan instruments are supplied as follows:

Instrument according to specification (without measuring head)

1 measuring head (DHM S1, DHM S2, CCM P1+TA-MI-701/TA-MI-708)

PC with 1 TFT screen

Nanaware Measure and Nanaware Analysis software (according to selected model)

User's manual (750 50 0028 03)

CODE NUMBER

TR Scan	Purpose	Meas. head	Axes	Software
TRS201CCM 700 405 20 11	Non-contact profiles measurements 2D	CCM P1	- 1 vertical axis Z - 1 horizontal axis X	Nanaware LT (2D analysis)
TRS201DHM 700 405 20 21	Extended profiles measurements 3D, metallic parts	DHM S2	- 1 vertical axis Z - 1 horizontal axis X	Nanaware STT (2D/3D analysis)
TRS301DHM 700 405 30 11	3D measurements, metallic parts	DHM S2	- 1 vertical axis Z - 2 horizontal axes XY	Nanaware STT (2D/3D analysis)

The TR Scan can also be specifically equipped according to the needs for each application (head(s) and measuring table, software). An exhaustive list of equipments can be found in the accessories section.

TR SCAN

APPLICATIONS



Surface spinning measurement on a steel printing roll (DHM S2)

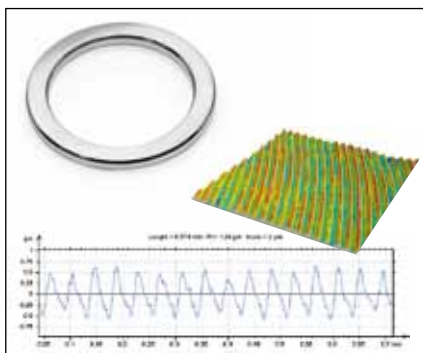

Verification of an aluminium ring joint gasket for the aircraft industry (DHM S2)

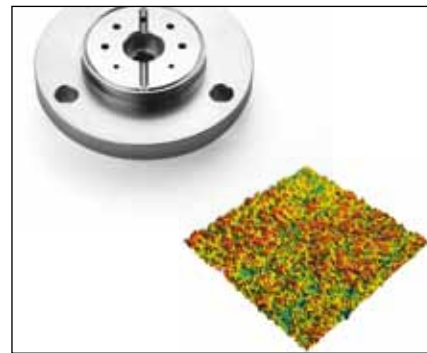

Texture analysis of a chemically polished titanium surface (DHM S2)

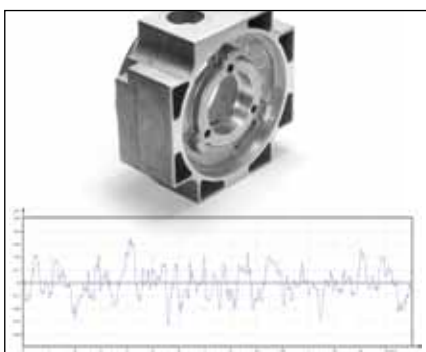

Classical 2D internal roughness measurement (DIA P1)

TR SCAN PREMIUM



TR SCAN PREMIUM

INTRODUCTION

TR Scan Premium allows the measuring of the most sensitive surfaces with astounding speed and precision. It has become unavoidable in many cases for hi-tech applications, when the traditional measuring by contact has reached its limits. Medical appliances, prosthesis, wafers, MEMS, semi-conductors, metallic layers deposits, polymer films, optical components, research and development, quality control, are the areas of expertise of TR Scan Premium.

The heart of the system, Trimos DHM® (Digital Holographic Microscopy), constitutes a derivation of a technology used in the biomedical engineering field. The system itself is based on the physical characteristics of the hologram for the topography generation of the analysed surface. This technology for checking industrial surfaces is exclusively used by Trimos. Its most distinctive feature to competitive products is the possibility of measuring extreme reflecting, mirror-polished or very small surfaces.

The exceptional high measuring speed coupled with an accuracy range of a nanometre form the main advantages of the TR Scan. Only some microseconds are needed for the acquisition of a three dimensional image (x, y, z) with a million points. This exceptional acquisition speed allows ignoring all problems traceable to vibrations, the traditional enemy of the majority of optical measuring systems. The mentioned advantages prove an enhanced productivity and a limited investment.

EXCEPTIONAL FAST MEASURING SPEED

INSENSITIVE TO VIBRATION

VERTICAL RESOLUTION IN NANOMETER RANGE

EXTREME SIMPLE POSITIONING OF THE PART THANKS TO LASER ALIGNMENT (DHM)

NON-CONTACT MEASURING, NON DESTRUCTIVE

SOFTWARE AT THE TOP OF THE TECHNOLOGY

PRE-PROGRAMMED MEASURING PROCESSES

COMPATIBLE WITH 2D AND 3D STANDARDS

DESCRIPTION

AUTOMATED Z-AXIS

The motorization of the axes allows entirely automatic measurements. The working distance is automatically given by the system. The measurement of surfaces wider than the field of vision of the lens is made possible thanks to a particularly efficient "stitching" function.



INTERCHANGEABLE MEASURING HEADS

The unique system of interchangeable measuring heads confers a high degree of adaptability to every application. Changing a head is quickly done and automatically recognized by the system. Several technologies are available for complete application coverage.

TRIMOS NANOWARE MEASURE

Software for the management of all measurement parameters

TRIMOS NANOWARE ANALYSIS

Software for the analysis of measured surfaces

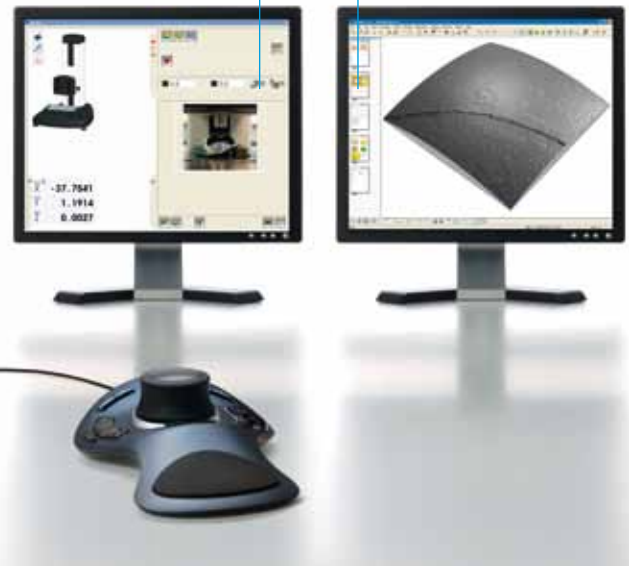

TR SCAN PREMIUM

DISPLAY / SOFTWARE

TRIMOS NANOWARE MEASURE

This exclusive software allows the handling of the instrument (positioning and configuration of all measurements).

Positioning in X,Y,Z is performed either automatically by pre-defined parameters or via the use of an intuitive joystick aided by a integrated positioning laser and a camera (optional).

Once positioned, measurements are taken automatically with one click or via the use of a manual size parameter in a few seconds.

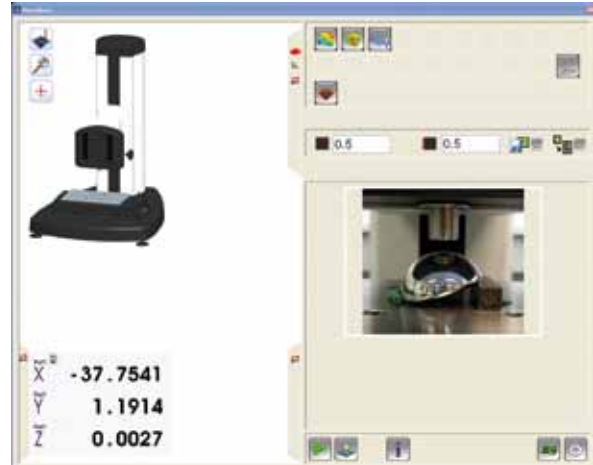

INTUITIVE POSITIONING

INSTANT MEASUREMENT

PROGRAMMABLE MEASUREMENTS WITH PICTURE

TRIMOS NANOWARE ANALYSIS

This software allows the analysis of all measured surfaces according to current international standards such as ISO, DIN, JIS, ASME, CNOMO etc., as well as the 3D standard ISO 25178.

Analysis can be performed automatically by the use of a template or the user can have direct access to the raw data. The incorporated analysis software is powered by Mountains®, the most powerful and recognized 2D/3D surface analysis software available.

Reports are automatically generated during analysis. Any report can be used as a template later.

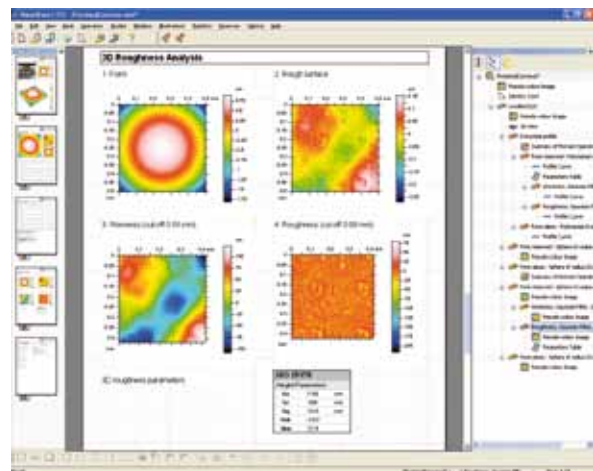

POWERFUL ANALYSIS

PROFESSIONAL REPORTING

SUITABLE MODULE FOR EACH APPLICATION NEED

COMPLIES TO ALL INTERNATIONAL STANDARDS

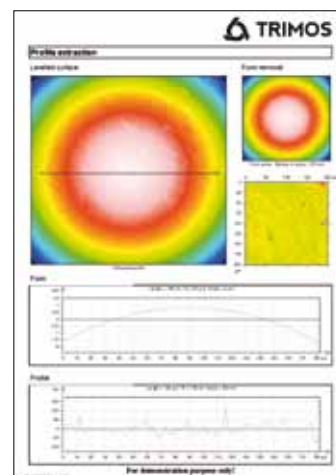

THE DHM TECHNOLOGY

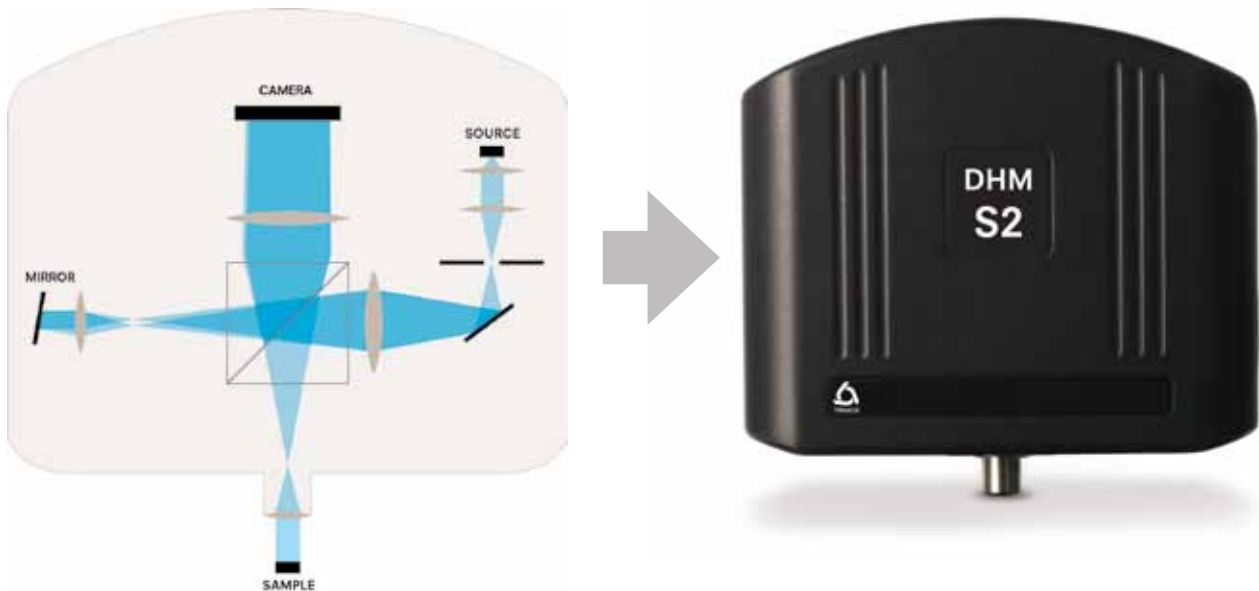

DHM® (Digital Holographic Microscopy) is a non-contact surface measurement technology originally developed for the biotech and medical industry. DHM generates a high-resolution 3D digital image of a sample using the principle of holography. A hologram generated by combining a coherent reference wave with the wave received from a sample is recorded by a CCD camera and transmitted to a computer for numerical reconstruction.

A single hologram is acquired in a few microseconds, making the whole system insensitive to vibrations. Software procedures allow computation of the complete wavefront emanating from an object and provides:

- Intensity images providing the same contrast as with classical optical microscopy

- Phase images providing quantitative data, defined at a sub-wavelength scale, used for accurate and stable 3D measurements.

The phase image reveals the surface topography with a sub-nanometric vertical resolution. This digital approach to holography allows the application of computer-based procedures at a level never reached in optical microscopy so far. In particular the DHM principle features software compensation of optical aberrations, digital image focusing and numerical compensation for sample tilt and environmental disturbances, making DHM instruments robust and easy to use for routine inspections at the nanometer and micrometer scale. DHM is used exclusively by Trimos for surface texture measurement. This technology has numerous advantages compared to other contact and non-contact measurement technologies: in particular extremely fast measurements, high resolution, simple working process no moving parts and no requirement for special environmental conditions.

- Acquisition in a few microseconds
- Vibration insensitive
- High image quality
- Subnanometric resolution
- No moving parts
- No requirement for special environmental conditions

DHM is a recognized surface texture measurement method according to the standard ISO 25178-6

TR SCAN PREMIUM

MEASURING HEADS

DHM S1 & S2

DHM Technology:

- Smooth, grinded and polished surfaces
- Steel, aluminum, titanium, silicon, gold, ceramics, glass
- High precision and speed, 2D/3D

CCM P1

Chromatic Confocal Technology:

- Machined and rough surfaces, micro-structures
- Metals, plastics, abrasives, papers, textiles, cosmetics
- Large vertical range, all materials, 2D/3D

DIA P1

Diamond Stylus Tip Technology:

- Roughness measurement with contact
- Classical roughness measurements (2D)
- Internal measurements

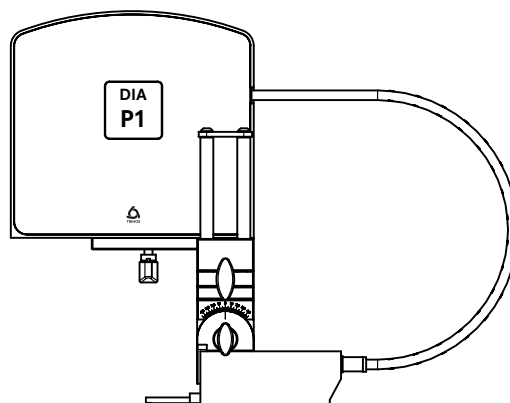
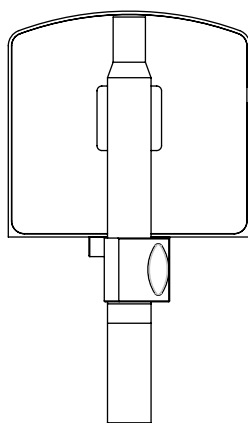
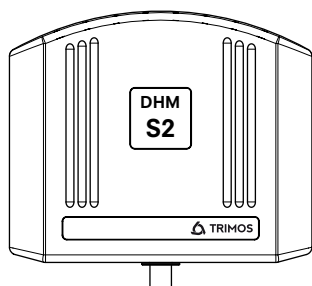

TECHNICAL SPECIFICATIONS

TR Scan Premium		101	301
Horizontal measuring range X	mm	-	100
Horizontal measuring range Y	mm	-	100
Vertical measuring range Z	mm	240	
Measuring system resolution XYZ	µm	0.1	
Positioning accuracy XYZ	µm	1	
Rectitude of the guideways XY	µm	0.3	
Max weight of the part	kg	20	

Measuring Heads		DHM S1	DHM S2	CCM P1	DIA P1
Vertical resolution (Z)	nm	0.1	0.1	8 ÷ 780 ²⁾	10
Lateral resolution (XY)	µm	0.6	0.6	0.9 ÷ 14 ²⁾	1
Typical measuring range Ra ¹⁾	µm	0.4	1.6	0.012 ÷ >200 ²⁾	20
Vertical measuring range ¹⁾	µm	3	7	130 ÷ 24000 ²⁾	350
Max. permissible errors Ra	%	1%	1%	1% ÷ 5% ²⁾	5%
Repeatability (Ra, 1σ)	nm	< 0.1	< 0.1	<5 ÷ 25 ²⁾	9
Sample reflectivity	%	< 1% ÷ 100%	< 1% ÷ 100%	1% ÷ 100%	-
Field of view	mm	0.25 x 0.25	0.25 X 0.25	-	-

¹⁾ Values may differ depending on the surface texture

²⁾ Objective dependent

DIAGRAM

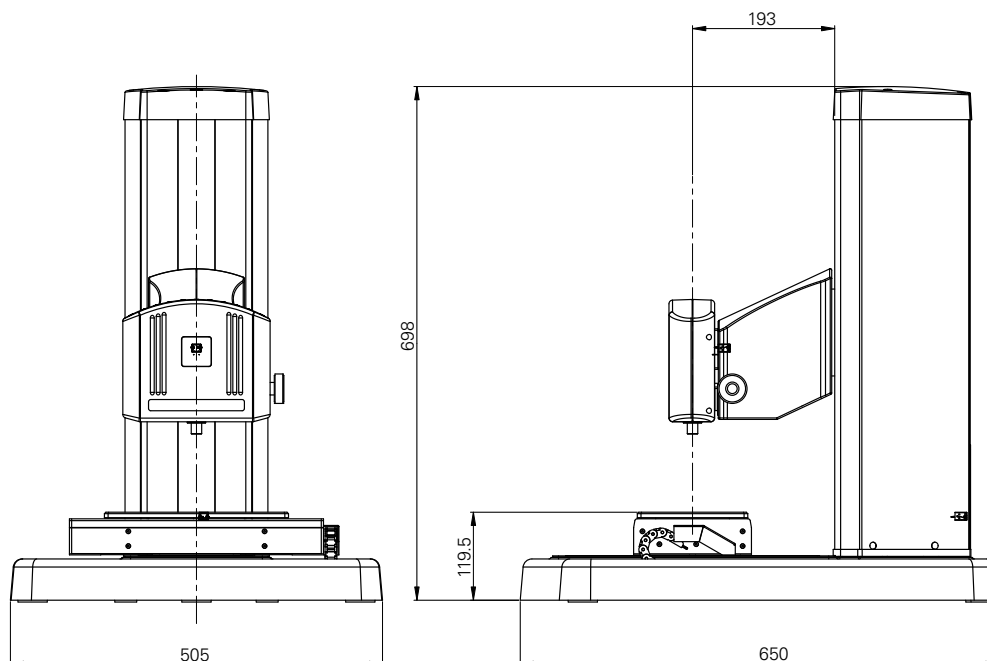

STANDARD INSTRUMENT

The TR Scan Premium instruments are supplied as follows:

Instrument according to specification (without measuring head)

1 measuring head (DHM S1, DHM S2, CCM P1+TA-MI-701 ÷ 713)

PC with 1 TFT screen

Nanaware Measure and Nanaware Analysis softwares (according to selected model)

User's manual (750 50 0028 03)

CODE NUMBER

TR Scan Premium	Purpose	Meas. head	Axes	Software
TRSP101DHM 700 405 10 11	3D Measurement of tiny parts	DHM S2	- 1 vertical axis Z	Nanaware STT (2D/3D analysis)
TRSP301DHM 700 405 30 21	3D measurement of metallic parts	DHM S2	- 1 vertical axis Z - 2 horizontal axes XY	Nanaware STT (2D/3D analysis)
TRSP301CCM 700 405 30 31	Universal 3D measurements	CCM P1	- 1 vertical axis Z 2 horizontal axes XY	Nanaware STT (2D/3D analysis)

TR Scan Premium can also be specifically equipped according to each application need (head(s) and measuring table, software). An exhaustive list of equipments can be found in the accessories section.

TR SCAN PREMIUM

APPLICATIONS

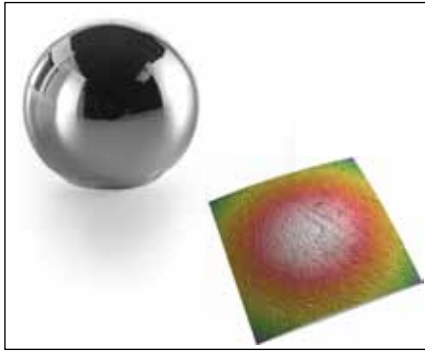

Quality control of a cobalt-chromium polished prosthesis surface (DHM-S2)

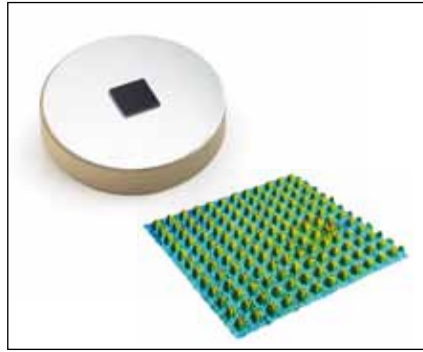

Analysis of a silicon microstructure (DHM S2)

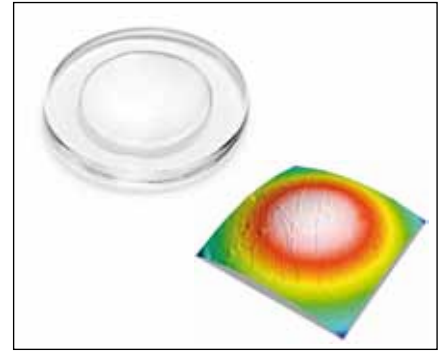

Roughness inspection of micro lenses (DHM S2)

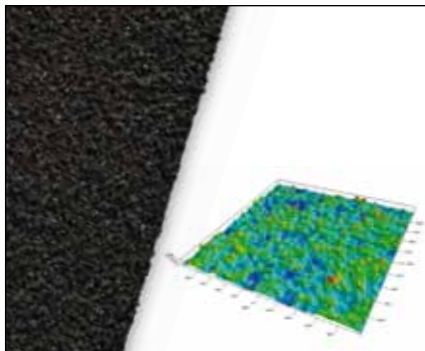

Surface texture analysis of an industrial abrasive material (CCM P1)

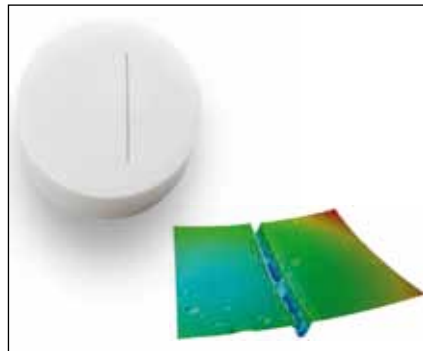

Depth measurement of a laser engraving on ceramics (CCM-P1)

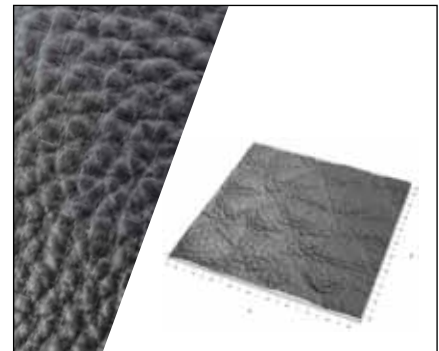

Topographic analysis of a leatherette sample (CCM-P1)

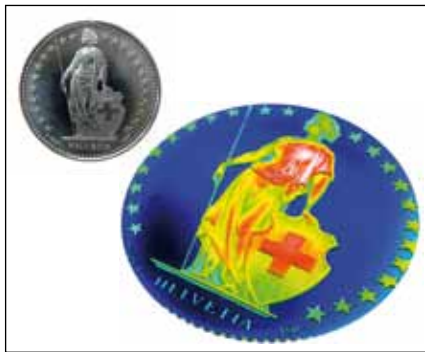

Measurement of macroscopic surface textures (CCM P1)

ACCESSORIES

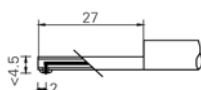

		TR Profile VH	TR Profile VHF	TR Profile DH-8 VH	TR Profile DH-8 VHF	TR Scan	TR Scan Premium
TA-MI-701 279 970000 001	Optical pen, with optical fiber and certificate, measuring range=130 μm , lateral resolution=0.9 μm					•	•
TA-MI-707 279 970001 001	Optical pen, with optical fiber and certificate, measuring range=130 μm , lateral resolution=1.4 μm					•	•
TA-MI-708 279 970001 002	Optical pen, with optical fiber and certificate, measuring range=400 μm , lateral resolution=1.2 μm					•	•
TA-MI-702 279 970000 002	Optical pen, with optical fiber and certificate, measuring range=400 μm , lateral resolution=1.7 μm					•	•
TA-MI-713 279 970002 002	Optical pen, with optical fiber and certificate, measuring range=400 μm , lateral resolution=3.5 μm					•	•
TA-MI-709 279 970001 003	Optical pen, with optical fiber and certificate, measuring range=1400 μm , lateral resolution=2 μm						•
TA-MI-703 279 970000 003	Optical pen, with optical fiber and certificate, measuring range=1400 μm , lateral resolution=4 μm						•
TA-MI-710 279 970001 004	Optical pen, with optical fiber and certificate, measuring range=4000 μm , lateral resolution=4 μm						•
TA-MI-704 279 970000 004	Optical pen, with optical fiber and certificate, measuring range=4000 μm , lateral resolution=7 μm						•
TA-MI-711 279 970001 005	Optical pen, with optical fiber and certificate, measuring range=12000 μm , lateral resolution=7 μm						•
TA-MI-705 279 970000 005	Optical pen, with optical fiber and certificate, measuring range=124000 μm , lateral resolution=12.37 μm						•
TA-MI-712 279 970001 006	Optical pen, with optical fiber and certificate, measuring range=24000 μm , lateral resolution=8 μm						•
TA-MI-706 279 970000 006	Optical pen, with optical fiber and certificate, measuring range=24000 μm , lateral resolution=14 μm						•
TA-MS-601 279 980001 001	Standard tracer, with skid R = 25 mm bore > \varnothing 8 mm, depth < 27 mm	•	•	•	•		



TR Profile VH



TR Profile VHF



TR Profile
DH-8 VH



TR Profile
DH-8 VHF



TR Scan



TR Scan
Premium

ACCESSORIES

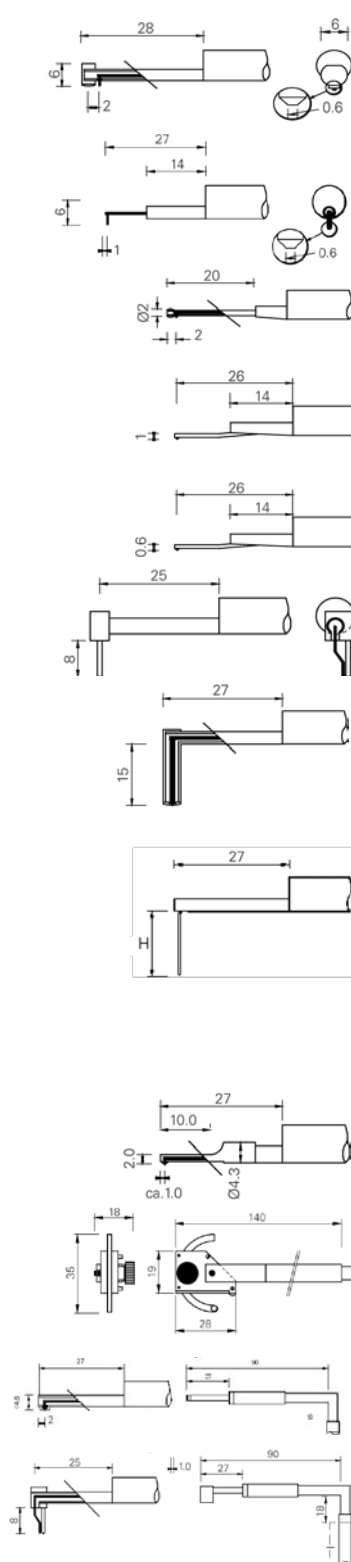

		TR Profile VH	TR Profile VHF	TR Profile DH-8 VH	TR Profile DH-8 VHF	TR Scan	TR Scan Premium
TA-MS-602 279 980001 002	Probe for small axes, knives, edges and wires with skid R=25 mm	●	●	●	●		
TA-MS-603 279 980001 003	Probe for small axes, knives, edges and wires without skid		●		●	●	●
TA-MS-604 279 980002 001	Bore probe with skid R=10 mm bore >Ø2.5 mm, depth < 20 mm	●	●	●	●		
TA-MS-605 279 980002 002	Bore probe, without skid bore >Ø1.5 mm, depth < 12 mm		●		●	●	●
TA-MS-606 279 980002 003	Small bore probe, without skid bore >Ø0.8 mm, depth < 12 mm		●		●	●	●
TA-MS-607 279 980003 001	Concave-convex probe, with skid R=1 mm for concave & convex workpieces with R>5 mm	●	●	●	●		
TA-MS-608 279 980004 001	Probe for slots, with skid R=25 mm slot depth < 15 mm, slot width > 3 mm	●	●	●	●		
TA-MS-612 279 980004 005	Probe for slots, H=5 mm, without skid slot depth < 5 mm, slot width > 1.0 mm		●		●	●	●
TA-MS-611 279 980004 004	Probe for slots, H=10 mm, without skid slot depth < 10 mm, slot width > 1.0 mm		●		●	●	●
TA-MS-609 279 980004 002	Probe for slots, H=15 mm, without skid slot depth < 15 mm, slot width > 1.5 mm		●		●	●	●
TA-MS-610 279 980004 003	Probe for slots, H=20 mm, without skid slot depth < 20 mm, slot width > 1.5 mm		●		●	●	●
TA-MS-620 279 980005 001	Probe for gear tooth profiles, with skid , module >= 2	●	●	●	●		
TA-MS-621 279 980006 001	Probe for circumference and balls, with skid for Ø >= 6 mm	●	●	●	●		
TA-MS-622 279 980007 001	Transverse probe, with skid R=25 mm	●	●	●	●		
TA-MS-623 279 980007 002	Transverse probe for slots, with skid R=1 mm slot depth < 7 mm	●	●	●	●		

ACCESSORIES

TR Profile VH
TR Profile VHF
TR Profile DH-8 VH
TR Profile DH-8 VHF
TR Scan
TR Scan Premium

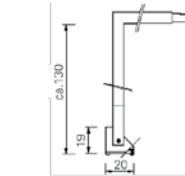
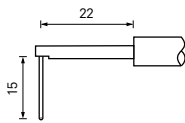
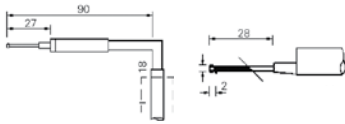

TA-MS-624 279 980007 003	Transverse probe for bores, with skid R=25 mm	●	●	●	●		
TA-MS-626 279 980007 004	Transverse probe left side, without skid		●		●	●	●
TA-MS-627 279 980007 005	Transverse probe right side, without skid		●		●		
TA-MS-625 279 980008 001	Depth measuring probe, with skid R=25mm depth < 130 mm	●	●	●	●		
TA-AD-601 279 980901 001	Extension 100 mm for probe	●	●	●	●		
TA-AD-602 279 980901 002	Extension 150 mm for probe	●	●	●	●		
TA-AD-603 279 980901 003	Extension 200 mm for probe	●	●	●	●		
TA-AD-604 279 980901 004	Extension 500 mm for probe	●	●	●	●		
TA-AD-605 279 980901 005	Extension 750 mm for probe	●	●	●	●		
TA-MS-650 279 980010 001	Contour tracer				●		
TA-MS-651 279 980010 002	Contour measurement kit - Simple (for TR Profile DH-8/VHF), Contour tracer (TA-MS-650) with standard (TA-MG-651), DIASOFT Standard (TA-SW-602) & contour module Simple (TA-SW-610)				●		
TA-MS-652 279 980010 003	Contour measurement kit - Advanced (for TR Profile DH-8/VHF, Contour tracer (TA-MS-650) with standard (TA-MG-651), DIASOFT Standard (TA-SW-602) & contour mod. Advanced (TA-SW-611)				●		
DHM-S1 709 70 001	Measuring head DHM S1					●	●
DHM-S2 709 70 002	Measuring head DHM S2					●	●



TR Profile VH



TR Profile VHF



TR Profile
DH-8 VH



TR Profile
DH-8 VHF



TR Scan



TR Scan
Premium

ACCESSORIES



		TR Profile VH	TR Profile VHF	TR Profile DH-8 VH	TR Profile DH-8 VHF	TR Scan	TR Scan Premium
CCM-P1 709 70 005	Measuring head CCM P1					•	•
DIA-P1 709 70 003	Measuring head DIA P1					•	•
TA-SU-601 279 981001 001	XY table, base plate 70 x 70 mm, travel range 25 x 25 mm	•	•	•	•		
TA-SU-602 279 981901 001	Vice for XY table TA-SU-601, opening 22mm	•	•	•	•		
TA-AD-606 279 982001 001	Measuring stand with drive unit holder with aluminium base and column H=250 mm	•	•	•	•		
TA-AD-608 279 982001 003	Measuring stand with drive unit holder with aluminium base and column H=500 mm	•	•	•	•		
TA-AD-607 279 982001 002	Measuring stand with drive unit holder with granite base and column H=250 mm	•	•	•	•		
TA-AD-610 279 982001 004	Measuring stand with drive unit holder with granite base and column H=500 mm	•	•	•	•		
TA-AD-609 279 982901 001	Drive unit holder	•	•	•	•		
TA-SU-603 279 989001 001	Set with measuring stand and XY meas. table TA-AD-606 and TA-SU-601	•	•	•	•		
TA-SU-604 279 989001 002	Set with measuring stand,XY meas. table and vice TA-SU-603 and TA-SU-602	•	•	•	•		
TA-SU-605 297 700003 001	Swivelling stand, with magnetic base	•	•	•	•	•	•
TA-SU-606 297 700004 001	Precision vice 15 x 15 x 50 mm	•	•	•	•	•	•
TA-SU-607 297 700004 002	Precision vice 25 x 25 x 75 mm	•	•	•	•	•	•
TA-SU-608 297 700004 003	Precision vice 35 x 35 x 100 mm	•	•	•	•	•	•

ACCESSORIES



		TR Profile VH	TR Profile VHF	TR Profile DH-8 VH	TR Profile DH-8 VHF	TR Scan	TR Scan Premium
TA-SU-609 297 700005 001	Support plate for vice TA-SU-606	•	•	•	•	•	•
TA-SU-610 297 700005 002	Support plate for vice TA-SU-607	•	•	•	•	•	•
TA-SU-611 297 700005 003	Support plate for vice TA-SU-608	•	•	•	•	•	•
TA-SE-601 605 01 021	Clamping set, TA-SU-605/TA-SU-607/TA-SU-610	•	•	•	•	•	•
TA-MG-609 278 980001 001	Roughness standard, Ra=3.0 µm	•	•	•	•	•	•
TA-MG-610 278 980001 002	Roughness standard, Ra=3.0 µm, with SCS certificate	•	•	•	•	•	•
TA-MG-611 278 980001 003	Roughness standard, Ra=1.0 µm	•	•	•	•	•	•
TA-MG-612 278 980001 004	Roughness standard, Ra=1.0 µm, with SCS certificate	•	•	•	•	•	•
TA-MG-601 278 980010 001	Roughness standard Ra=25 nm, with DKD Certificate					•	•
TA-MG-602 278 980010 002	Roughness standard Ra=50 nm, with DKD Certificate					•	•
TA-MG-603 278 980010 003	Roughness standard Ra=80 nm, with DKD Certificate					•	•
TA-MG-605 278 980010 005	Roughness standard Ra=0.2 µm, with DKD Certificate	•	•	•	•	•	•
TA-MG-606 278 980010 006	Roughness standard Ra=0.5 µm, with DKD Certificate	•	•	•	•	•	•
TA-MG-607 278 980010 007	Roughness standard Ra=1.5 µm, with DKD Certificate	•	•	•	•	•	•
TA-MG-604 278 980010 004	Set of roughness standards Ra=25/50/80 nm with DKD Certificate					•	•
TA-MG-608 278 980010 008	Set of roughness standards Ra=0.2/0.5/1.5 µm with DKD Certificate	•	•	•	•	•	•
TA-MG-651 278 980001 011	Contour standard	•	•	•	•	•	•
TA-MG-652 278 980001 012	Contour standard, with SCS certificate	•	•	•	•	•	•
TA-EL-040 358 0020	Joystick					•	•



TR Profile VH



TR Profile VHF



TR Profile
DH-8 VH



TR Profile
DH-8 VHF



TR Scan



TR Scan
Premium

ACCESSORIES



DIASOFT



		TR Profile VH	TR Profile VHF	TR Profile DH-8 VH	TR Profile DH-8 VHF	TR Scan	TR Scan Premium
LABC-40 356 0010	Laser printer (USB)					•	•
TA-EL-030 356 0016	Inkjet printer (USB)					•	•
TA-EL-001 332 10 0011	Power cable, 2 poles, Europe					•	•
TA-EL-002 332 10 0013	Power cable, 2 poles, USA/Japan					•	•
TA-EL-003 332 10 0016	Power cable, 2 poles, Australia					•	•
TA-EL-004 332 10 0014	Power cable, 2 poles, UK					•	•
TA-EL-005 616 20 003	Power cable, 2 poles, Korea					•	•
TA-SW-601 394 1 3301	Software DIASOFT Basic, Predefined protocol, roughness and Abbott curve,(Ra, Rq, Rv, Rp, Rt, Sm, Rsk, Rku, Rz, RTp, RHTp, RDq, RPe)	•	•	•	•		
TA-SW-602 394 1 3302	Software DIASOFT Standard, Same as TA-SW-601 + individual protocols, zoom, symmetry, profile comparison, (RLq, Rlo, RzJIS, R3z)	•	•	•	•		
TA-SW-603 394 1 3303	Software DIASOFT Automotive , Same as TA-SW-602 + additionally with ISO 12085 (CNOMO), and ISO 13565, (parameter Rk)	•	•	•	•		
TA-SW-604 394 1 3304	Software DIASOFT Expert. The most complete software for roughness measurement	•	•	•	•		
TA-SW-610 394 1 3310	Module DIASOFT Contour Simple (for TA-SW-602/603/604)					•	
TA-SW-611 394 1 3311	Module DIASOFT Contour Advanced (for TA-SW-602/603/604)					•	
TA-SW-612 394 1 3312	Module DIASOFT Statistics (roughness) (for TA-SW-602/603/604)	•	•	•	•		
Nanoware LT 616 60 010	Module for profile analysis NanoWare LT profile measurement 2D - Basic					•	•
Nanoware XT 616 60 011	Module for profile analysis Nanoware XT profile measurements 2D - Advanced					•	•
Nanoware STT 616 60 012	Module for profile and surface analysis NanoWare STT, 3D roughness Software - Basic					•	•
Nanoware XTT 616 60 013	Module for profile and surface analysis Nanoware XTT, Roughness software 3D - Advanced					•	•
Nanoware PRO 616 60 014	Complete module for profiles and surfaces NanoWare PRO, Roughness software 3D - Professional					•	•