

HC-Line

New Generation of Calibration Instruments

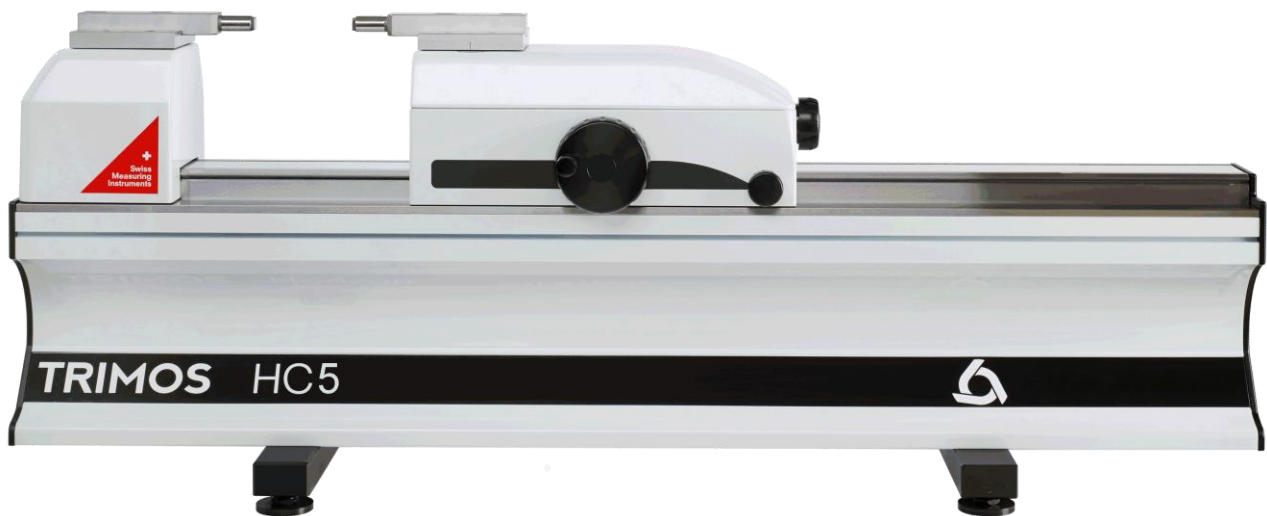

1.



PRESENTATION

The HC-line is designed for the calibration of fixed and variable dimension measuring equipment. The ergonomic design and reliability of these instruments, as well as their accuracy and ease of use, meet the most stringent requirements and increase the productivity of any laboratory.

The instruments are computer controlled. The exclusive WinDHI software makes it easy to perform all measurement functions. A temperature compensation system as well as a gauge inspection software can be installed to complement the performance of the instrument.

Instruments with a measuring range of 300 to 3000 mm are available, all manufactured in one piece. All measuring ranges are direct, i.e. the full measuring range is available without intermediate adjustment or recalibration.

- Quick displacement of the measuring carriage
- Adjustable force from ~1N to ~12N continuously
- Electronic monitoring of the measuring force
- Optical and acoustic indication of the measuring position
- 0.1 µm resolution
- Windows 10 & 11 compatible
- Wide range of display options
- Complies with the requirements of the ISO 9000 standard

HC3	HC4	HC5	Range (mm)	
		■	300	
■	■	■	500	
■	■	■	1000	
■	■		1500	
■	■		2000	
■	■		3000	

2.

APPLICATIONS

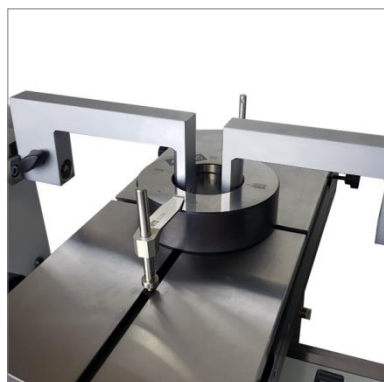

Calibration of plain ring gauges
(TA-SU-313, TA-MI-371, TA-SU-354, HPA-1)

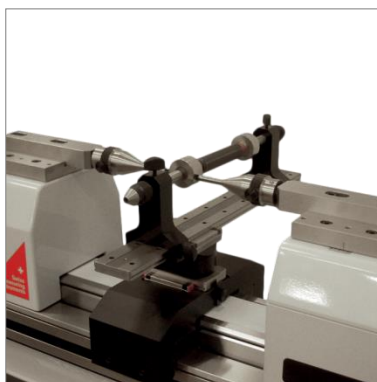

Calibration of plain plug gauges
(HPA-1, TULM6/L05, LABC-15)



Calibration of small plain ring gauges
(TA-SU-313, TA-MS-370, TEL76, TA-SU-354)



Calibration of threaded ring gauges
(TA-SU-313, TA-MS-370, TA-SU-354, TUML13.2, TA-MS-307)



Calibration of threaded plug gauges
(HPA-1, TEL6, 3P/0.17-3.2 /S6.5, LABC-15)

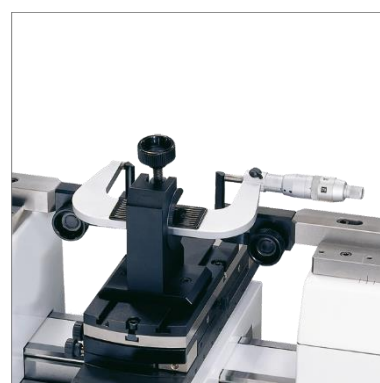

Calibration of external micrometers
(TA-SU-313, HPA-1, TULM14)



Comparative control of gauge blocks 100 ÷ 250 mm
(TA-SU-313, TA-SU-305)

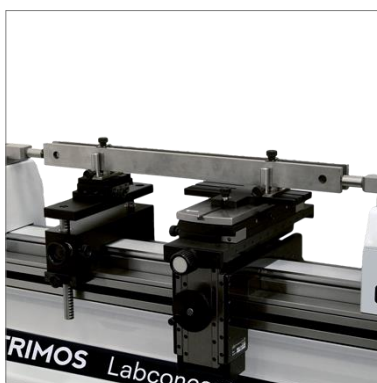

Comparative control of gauge blocks > 250 mm
(TA-SU-313, TELMA7/P, TA-SU-305, TA-SU-306)



Calibration of 2-point internal micrometers
(HPA-1, TELMA7, TELMN7.2)

3.

TECHNICAL DATA

HC3		500	1000	1500	2000	3000
Measurement range	mm	550	1050	1550	2050	3050
Maximum permissible errors, $B_{MPE}^{1)}$	μm	0.6+L/1200				
Repeatability, R_{MPE} (2s)	μm	0.1				
Maximal resolution	mm	0.00001				
Adjustable measuring force	N	0.3 / ^{2,3)} 0.5 / ^{2,3)} 1 \div 12 ³⁾				
Maximum travel speed	mm/s	4000				
Operating temperature	$^{\circ}\text{C}$	+10 \div +40				
Relative humidity	%	20 \div 80				
Weight	kg	94	123	152	181	239

HC4		500	1000	1500	2000	3000
Measurement range	mm	550	1050	1550	2050	3050
Maximum permissible errors, $B_{MPE}^{1)}$	μm	0.3+L/2000				
Repeatability, R_{MPE} (2s)	μm	0.1				
Maximal resolution	mm	0.00001				
Adjustable measuring force	N	0.3 / ^{2,3)} 0.5 / ^{2,3)} 1 \div 12 ³⁾				
Maximum travel speed	mm/s	4000				
Operating temperature	$^{\circ}\text{C}$	+10 \div +40				
Relative humidity	%	20 \div 80				
Weight	kg	94	123	152	181	239

HC5		300	500	1000
Measurement range	mm	350	550	1050
Maximum permissible errors, $B_{MPE}^{1)}$	μm	0.1+L/2000	0.15+L/2000	
Repeatability, R_{MPE} (2s)	μm	0.05		
Maximal resolution	mm	0.00001		
Adjustable measuring force	N	0.3 / ^{2,3)} 0.5 / ^{2,3)} 1 \div 12 ³⁾		
Maximum travel speed	mm/s	4000		
Operating temperature	$^{\circ}\text{C}$	+10 \div +40		
Relative humidity	%	20 \div 80		
Weight	kg	78	94	123

1) Values determined at a temperature of 20 ± 0.2 $^{\circ}\text{C}$ and a relative humidity of 50 ± 5 %.

2) With electronic probe

3) Force display in the WinDHI software window only

